

SECTION THROUGH CENTER OF MOONPOOL

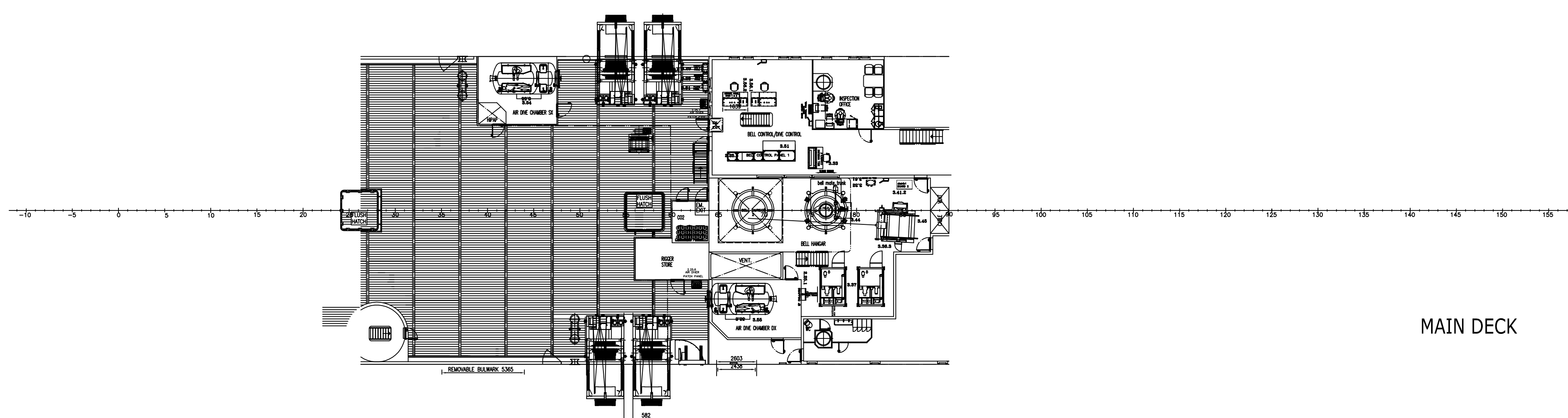

MAIN DECK

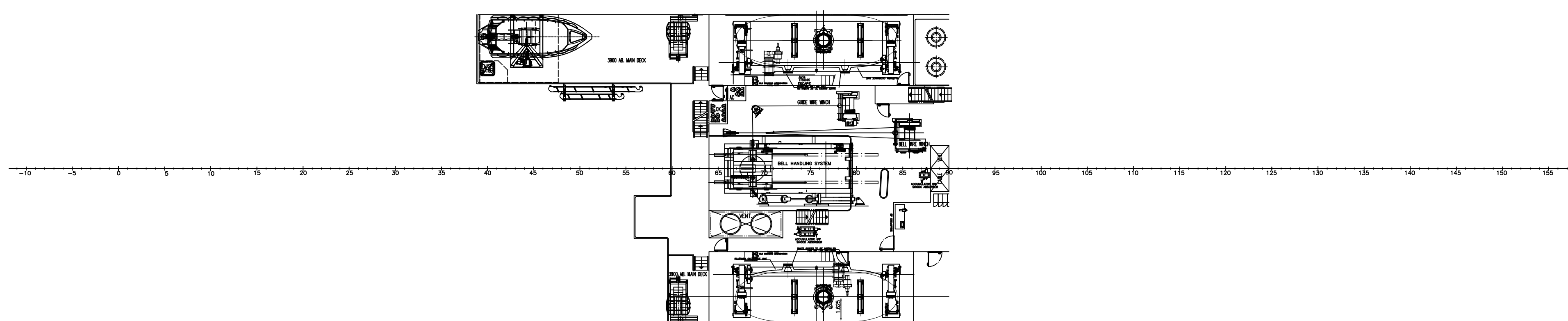
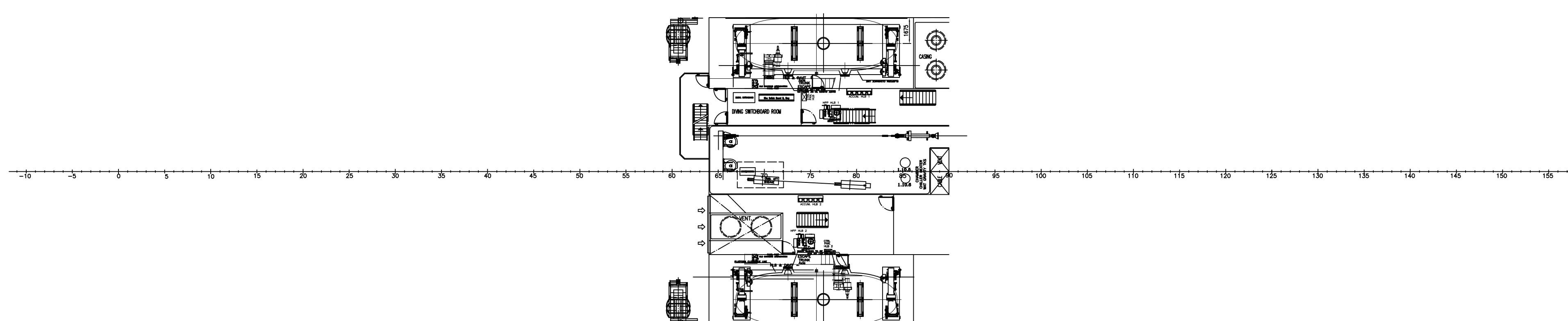
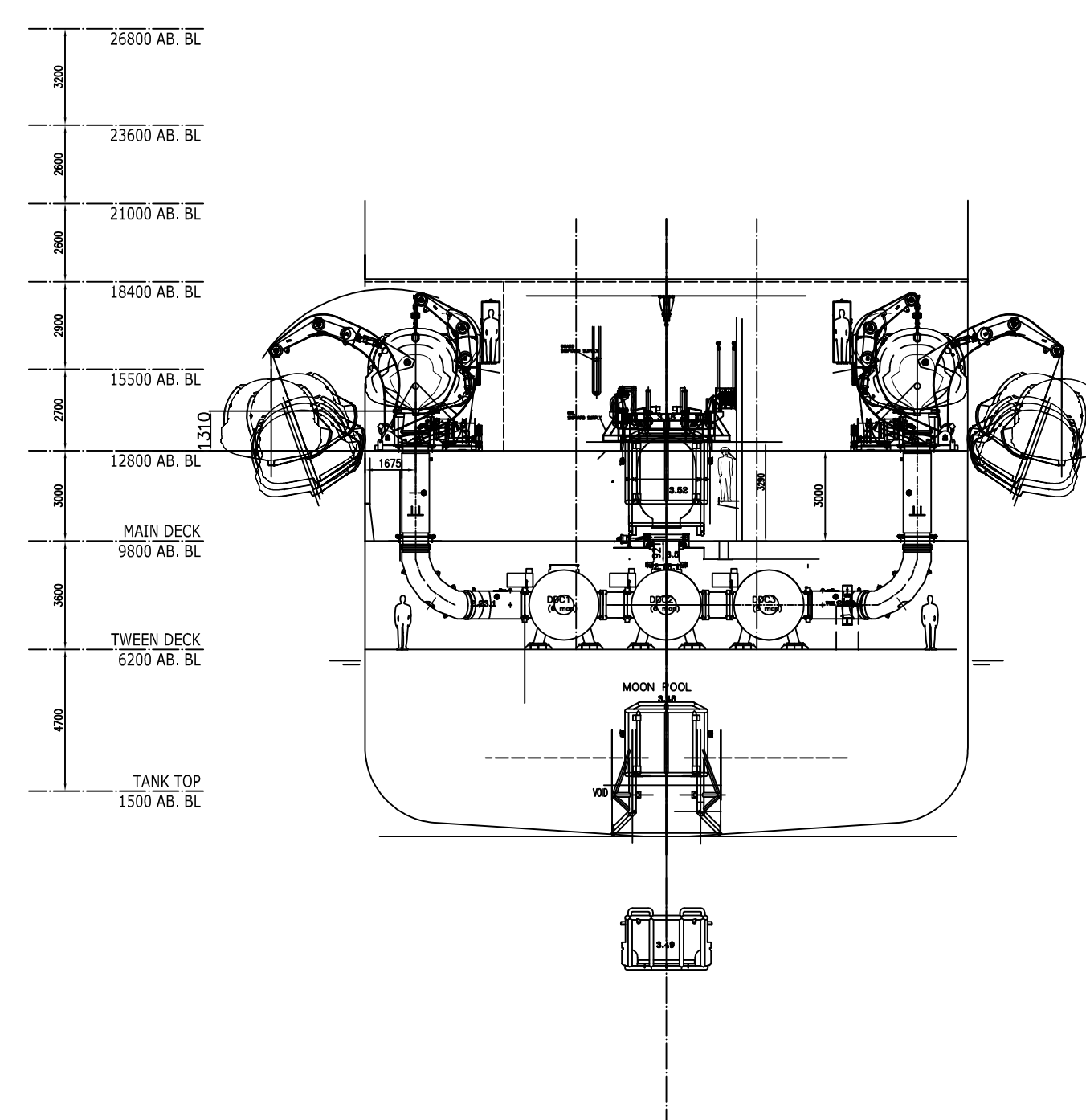
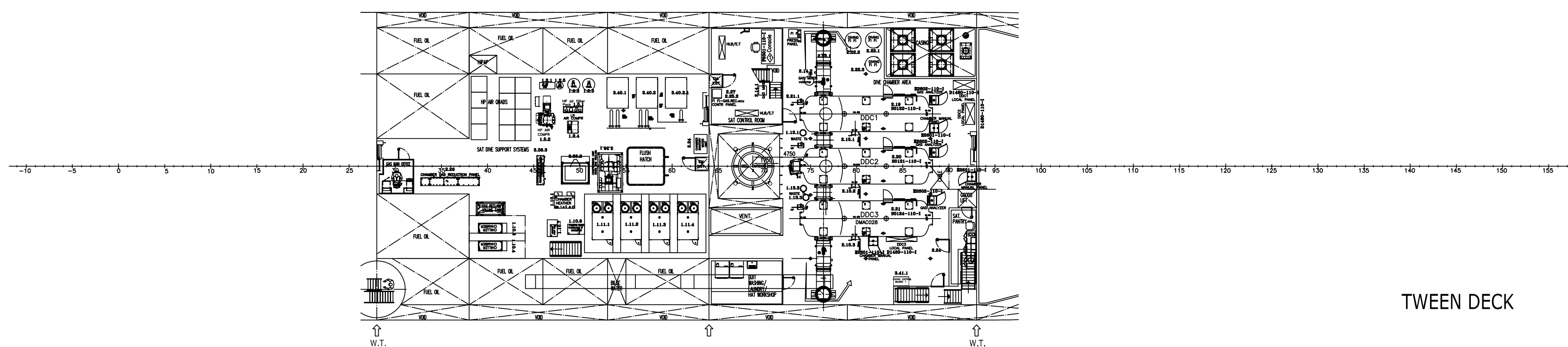

TWEEN DECK

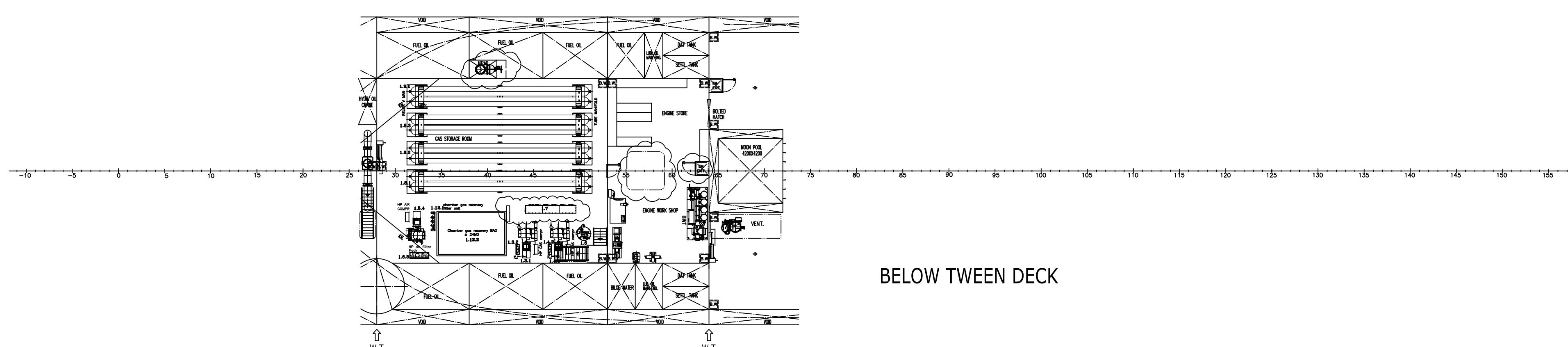

BELOW TWEEN DECK

CLASS: DNV +1A1, E0, SF, CLEAN DESIGN, DYNPOS-AUTR, DK(+)
 DSV-SAT, DSV-SURFACE, CRANE, COMF-V(3)-C(3),
 HELDK-SH, FIFI-I, NAUT-OSV(A), ICE-C, BIS,
 OFFSHORE SERVICE VESSEL+ SUPPLY

DSV-SAT SYSTEM: SINGLE BELL, 18 MEN
 DEPTH: 300 msw

DATE: 07/25/2011	DRAWN BY: NICOLA BOCCETTI	CHECKED BY: NICOLA BOCCETTI	SCALE: 1:1	NATO CODE: A0998	WHERE NOT INDICATED REMOVE SHARP EDGES	
5. DSV-SAT SYSTEM: SINGLE BELL, 18 MEN	4. DSV-SAT SYSTEM: SINGLE BELL, 18 MEN	3. DSV-SAT SYSTEM: SINGLE BELL, 18 MEN	2. DSV-SAT SYSTEM: SINGLE BELL, 18 MEN	1. DSV-SAT SYSTEM: SINGLE BELL, 18 MEN	PROJECT CODE: T0001-110 PROJECT NAME: 18 MAN 300 MSW DIVING SYSTEM GENERAL LAYOUT Project: 110 Size: A0 Draw: T0001-110 Scale: N.A. Rev: 5 Sheet: 1/1	