



ResMed

Lumis™ series

VPAP ST-A



Clinical guide
English

Contents

Welcome	1
Indications for use	1
Lumis 150 VPAP ST-A	1
Contraindications	1
Adverse effects	1
At a glance	1
About your device	2
About the control panel	3
Therapy information	4
CPAP mode	4
Bilevel modes	4
S (Spontaneous) mode	4
ST (Spontaneous/Timed) mode	4
T (Timed) mode	4
PAC (Pressure Assist Control) mode	4
iVAPS (intelligent Volume Assured Pressure Support) mode	4
More about iVAPS	7
Target alveolar ventilation	8
intelligent Backup Rate (iBR)	9
AutoEPAP	10
Triggering and cycling	11
TiControl - Inspiratory time control	11
Rise time adjustment	12
Leak management with VSync	12
Comfort features	12
Ramp	12
Ramp Down	13
Climate Control	13
Climate Control Auto	14
Climate Control Manual	14
Setup	15
Supplemental oxygen	16
Antibacterial filters	16
Accessing and exiting the Clinical Menu	17
Adjusting the clinical settings	17
Setting the date and time	18
QuickNav	18
Settings menu	19
Therapy	19
Comfort	21
Accessories	21
Alarms	22
Options	22
Configuration	23
Configuring iVAPS	24
Using Learn Targets	24
Entering the target values manually	24
Working with alarms	25
Muting activated alarms	25

Viewing the alarms.....	26
Alarm log.....	26
Alarm types.....	26
Testing the alarms.....	26
Starting therapy.....	28
Stopping therapy.....	28
Viewing the Sleep Report.....	28
Sleep Report screen parameters.....	29
Cleaning and Maintenance.....	30
Disassembling.....	30
Cleaning.....	31
Checking.....	31
Reassembling.....	31
Reprocessing.....	32
Surface disinfection.....	32
Reprocessing the air tubing and Air10 tubing elbow.....	33
Disconnecting.....	33
Decontaminating.....	33
Disinfecting.....	33
Inspecting.....	34
Reconnecting the air tubing.....	34
Packaging and storage.....	35
Reprocessing the humidifier and air outlet.....	35
Disassembling.....	35
Decontaminating.....	36
Disinfecting.....	36
Inspecting.....	37
Reassembling.....	37
Packaging and storage.....	38
Data management and therapy compliance.....	38
Remote monitoring.....	38
SD card.....	38
Data storage.....	39
Software upgrade.....	40
Managing patient care.....	40
Patient menu.....	40
Therapy data.....	40
Travelling.....	40
Travelling by plane.....	41
Troubleshooting.....	41
General troubleshooting.....	41
Alarms troubleshooting.....	43
General warnings and cautions.....	45
Technical specifications.....	46
Symbols.....	51
Servicing.....	51
Limited warranty.....	51

Welcome

The Lumis™ 150 VPAP ST-A is a bilevel positive airway pressure device.

WARNING

- Read this entire guide before using the device.
- Use the device according to the intended use provided in this guide.
- The advice provided by your prescribing doctor should be followed ahead of the information provided in this guide.

Indications for use

Lumis 150 VPAP ST-A

The Lumis 150 VPAP ST-A device is indicated to provide non-invasive ventilation for patients weighing more than 13 kg or more than 30 kg in iVAPS mode with respiratory insufficiency or obstructive sleep apnoea (OSA). It is intended for home and hospital use.

The humidifier is intended for single patient use in the home environment and re-use in a hospital/institutional environment.

Contraindications

Positive airway pressure therapy may be contraindicated in some patients with the following pre-existing conditions:

- severe bullous lung disease
- pneumothorax or pneumomediastinum
- pathologically low blood pressure, particularly if associated with intravascular volume depletion
- dehydration
- cerebrospinal fluid leak, recent cranial surgery, or trauma.

Adverse effects

Patients should report unusual chest pain, severe headache, or increased breathlessness to their prescribing physician. An acute upper respiratory tract infection may require temporary discontinuation of treatment.

The following side effects may arise during the course of therapy with the device:

- drying of the nose, mouth, or throat
- nosebleed
- bloating
- ear or sinus discomfort
- eye irritation
- skin rashes.

At a glance

The Lumis includes the following:

- Device
- HumidAir™ humidifier (if supplied)
- Air tubing
- Power supply unit
- Travel bag
- SD card (already inserted).

Contact your care provider for a range of accessories available for use with the device including:

- Air tubing (heated and non-heated): ClimateLineAir™, ClimateLineAir Oxy, SlimLine™, Standard
- HumidAir humidifier
- Side cover for use without the humidifier
- Filter: Hypoallergenic filter, standard filter
- Air10™ DC/DC converter (12V/24V)
- SD card reader
- Air10 oximeter adapter
- Air10 USB adapter
- Power Station II
- Air10 tubing elbow

Note: Make sure all parts and accessories used with the device are compatible. For compatibility information, refer to www.resmed.com.

About your device

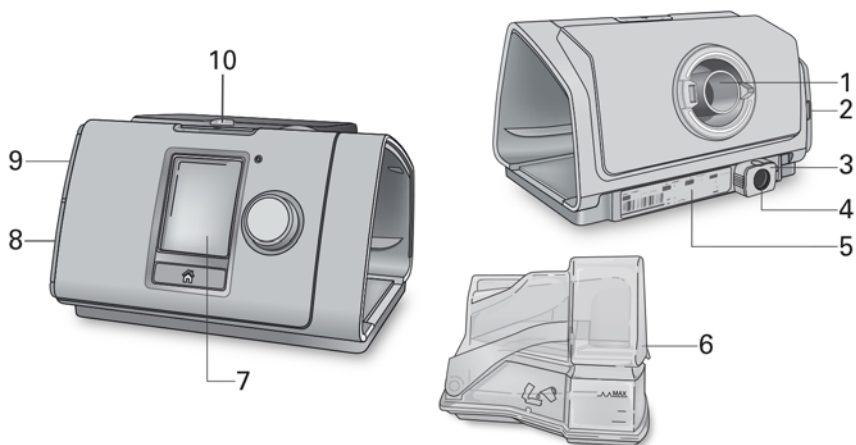

- | | | | |
|---|---------------------------------|----|---------------------|
| 1 | Air outlet | 6 | HumidAir humidifier |
| 2 | Air filter cover | 7 | Screen |
| 3 | Retention clip | 8 | Adapter cover |
| 4 | Power inlet | 9 | SD card cover |
| 5 | Serial number and device number | 10 | LED alarm indicator |

About the control panel



Start/Stop button

Press to start/stop therapy.
Press and hold for three seconds to enter power save mode.



Dial

Turn to navigate the menu and press to select an option.
Turn to adjust a selected option and press to save your change.



Home button

Press to return to the Home screen.

Different icons may be displayed on the screen at different times including:



Ramp Time



Wireless signal strength (green)



Humidity



Wireless transfer not enabled (grey)



Humidifier warming



No wireless connection



Humidifier cooling



Airplane Mode



Alarm muted

Therapy information

CPAP mode

In CPAP mode, a fixed pressure is delivered.

Bilevel modes

The Lumis device assists spontaneous breathing by cycling between two pressures in response to the patient flow or a preset fixed time.

The inspiratory positive airway pressure (IPAP, or the sum of EPAP and the pressure support level) assists inspiration.

The lower expiratory positive airway pressure (EPAP) facilitates exhalation comfort while providing a splint to maintain an open upper airway.

The difference of the two pressures—pressure support (PS) level—contributes to improved patient ventilation.

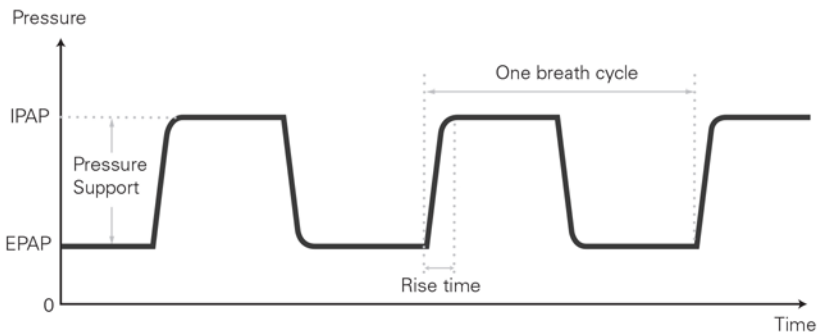

S (Spontaneous) mode

In S mode, you may set two treatment pressures—one for inspiration (IPAP) and one for expiration (EPAP). The device senses when the patient is inhaling and exhaling and supplies the pressures accordingly. The difference between IPAP and EPAP levels helps determine the tidal volume.

ST (Spontaneous/Timed) mode

In ST mode, the device augments any breath initiated by the patient, but will also supply additional breaths should the patient breath rate fall below the set Backup Rate.

T (Timed) mode

In T mode, a fixed breath rate and a fixed inspiration/expiration time are supplied regardless of patient effort.

PAC (Pressure Assist Control) mode

The inspiration time is preset in the PAC mode. There is no spontaneous/flow cycling. The inspiration can be triggered by the patient when respiratory rate is above a preset value, or time triggered breath will be delivered at the set Backup Rate.

iVAPS (intelligent Volume Assured Pressure Support) mode

iVAPS is designed to maintain a preset target alveolar minute ventilation by monitoring delivered ventilation, adjusting the pressure support and providing an intelligent backup breath automatically. The iVAPS therapy mode is indicated for patients weighing 66 lb (30 kg) and above.

The following diagram illustrates these operating modes.

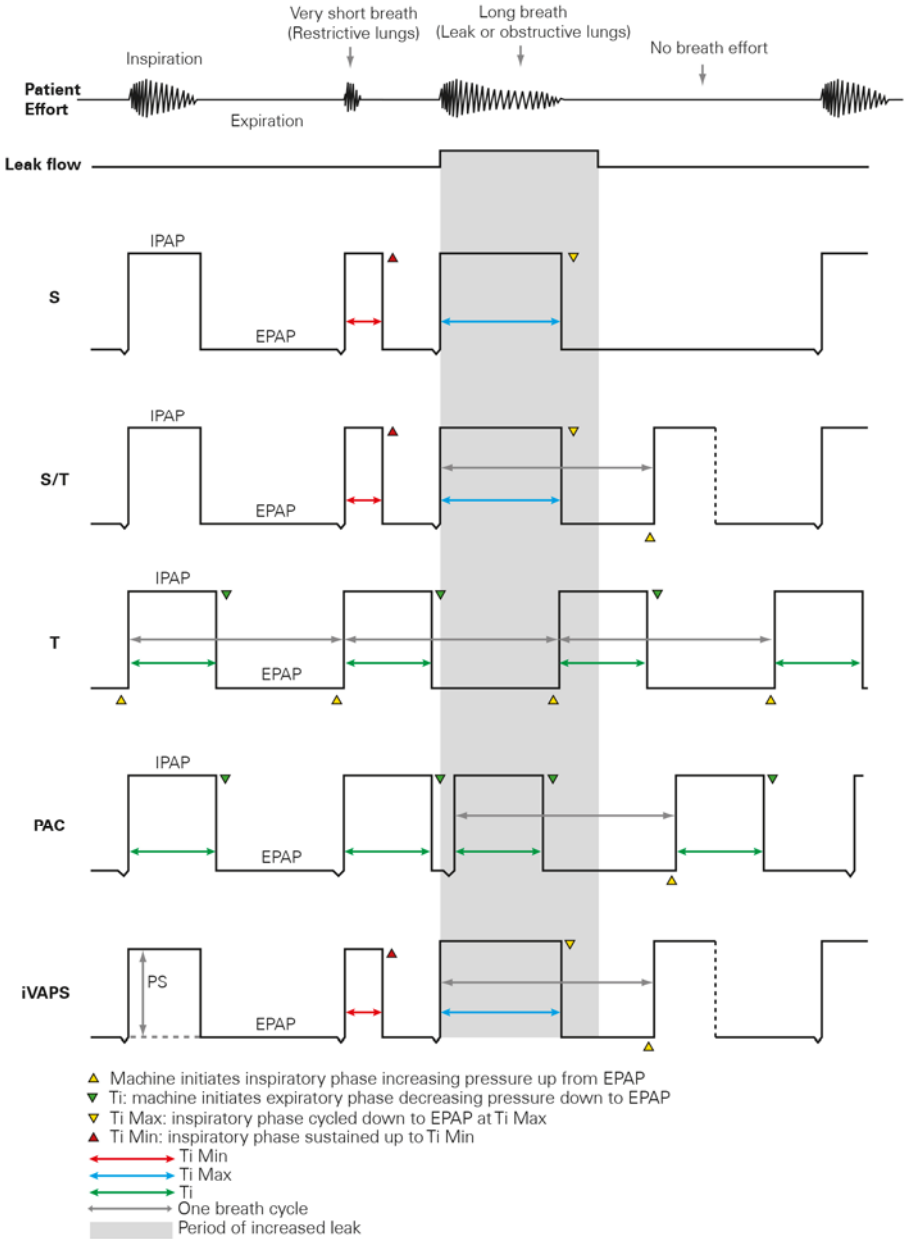

The common adjustable parameters for different modes in the Lumis device are shown below.

Parameter	Mode					
	S	ST	T	PAC	iVAPS	CPAP
Set Pressure						✓
IPAP	✓	✓	✓	✓		
EPAP	✓	✓	✓	✓	✓	
Min PS					✓	
Max PS					✓	
Min EPAP*					✓	
Max EPAP*					✓	
Resp. Rate			✓			
Backup Rate		✓				
Target Pt Rate**		✓			✓	
Target Va					✓	
Ti			✓	✓		
Ti Max	✓	✓			✓	
Ti Min	✓	✓			✓	
Rise Time	✓	✓	✓	✓	✓	
Trigger	✓	✓		✓	✓	
Cycle	✓	✓			✓	
Height					✓	

*Only available when AutoEPAP is enabled.

**Only available when iBR is enabled in ST mode.

More about iVAPS

You may prefer some assurance that the patient's ventilatory needs will be defended if their condition varies. A variety of 'dual mode' schemes exist, that aim to combine the benefits of pressure target and volume target, most of which can be categorized generically as volume-assured pressure support (VAPS) modes.

With VAPS devices in general, the ventilatory assistance (pressure support) aims to automatically adjust to changes in patient condition over time, typically to maintain a target tidal volume.

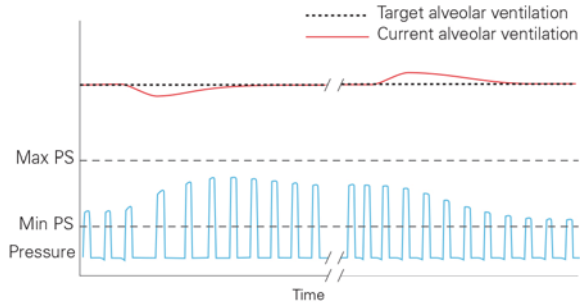

iVAPS offers the comfort and synchrony of pressure support, but with the assurance offered by a volume target. iVAPS has the following advantages over traditional VAPS schemes:

- iVAPS is a unique combination for a servo-controlled ventilator, in that iVAPS has the goal of regulating alveolar ventilation to a prescribed target, and iVAPS has a swift but gentle servocontrol response. iVAPS is tuned to be fast enough to avoid blood-gas derangement associated with most breathing challenges, including during sleep, but is gentle enough to avoid disruption.
- iVAPS has an intelligent Backup Rate (iBR) which aims to keep 'out of the way' while the patient is breathing, yet during sustained apnoea will mimic the patient's own breath rate. This contributes to iVAPS' ability to maintain its ventilation target and so stabilise blood gases even during sleep.
- iVAPS has ResMed's robust leak compensation algorithm (Vsync). This promotes synchrony and comfort even during significant leak.

Target alveolar ventilation

iVAPS targets alveolar ventilation. Alveolar ventilation was chosen because gas exchange occurs at the alveoli level. Total ventilation includes the ventilation devoted to the conducting airways, whereas alveolar ventilation best represents the useful portion of ventilation that reaches the alveoli. Alveolar ventilation cannot be measured directly, so iVAPS estimates it using a height approximated value of anatomical deadspace as shown in the graph below. Anatomic deadspace is the amount of breath that remains in the conducting airways, that does not reach alveoli and does not contribute to gas exchange. Its contribution is proportional to breath rate. By using alveolar ventilation as a servo-ventilation target, as opposed to tidal volume or minute ventilation, the effect of respiratory rate change on effective ventilation is negated.

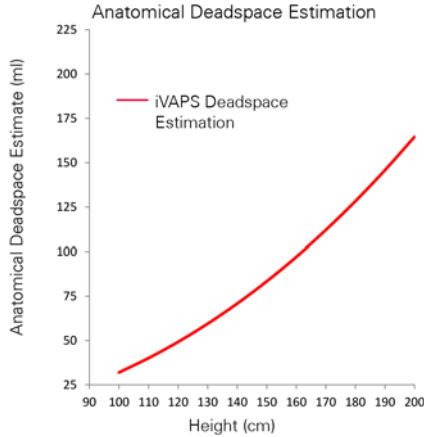

Adapted from Hart MC et al. Journal Applied Physiology, 18(3), p519-522. 1963

intelligent Backup Rate (iBR)

ST and iVAPS modes only

Instead of mandating a fixed backup rate, the intelligent Backup Rate (iBR) will shift automatically between two limits.

During sustained apnoea, the iBR will adopt a pre-configured Target Patient Rate. This Target Patient Rate defines the upper boundary for iBR. Set the Target Patient Rate to match the patient's average spontaneous rate (unlike a traditional backup rate).

During spontaneous ventilation, the iBR adjusts to remain in the background, at two-thirds of the Target Patient Rate. This 'background' backup rate is lower than a traditional S/T rate, so gives the patient maximum opportunity to spontaneously trigger.

When spontaneous triggering ceases (eg, at the onset of an apnoea/hypopnoea), the iBR adjusts from its background frequency to its Target Patient Rate in iVAPS mode and adjusts quickest (within 4 to 5 breaths) when ventilation is below the target ventilation. In ST mode, iBR adjusts to the Target Patient Rate at a fixed 5 breaths.

A single spontaneous triggered breath resets the iBR to its background rate (two-thirds of Target Patient Rate).

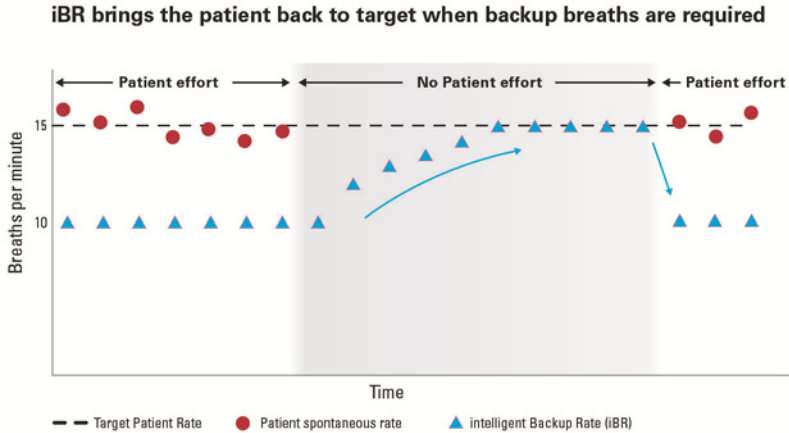

AutoEPAP

iVAPS mode only

The purpose of AutoEPAP is to maintain upper airway patency. AutoEPAP automatically adjusts pressure in response to flow limitation or obstruction of the upper airway. EPAP is adjusted within Min EPAP and Max EPAP settings with the response depending on the degree of the upper airway obstruction.

Pressure support is adjusted on top of the AutoEPAP. The maximum delivered pressure, EPAP plus pressure support, is limited to the maximum pressure of the device. If the sum of AutoEPAP plus pressure support exceeds the maximum pressure limit, pressure support is sacrificed to maintain airway patency (ie, EPAP). However, pressure support will not drop below the set minimum pressure (Min PS).

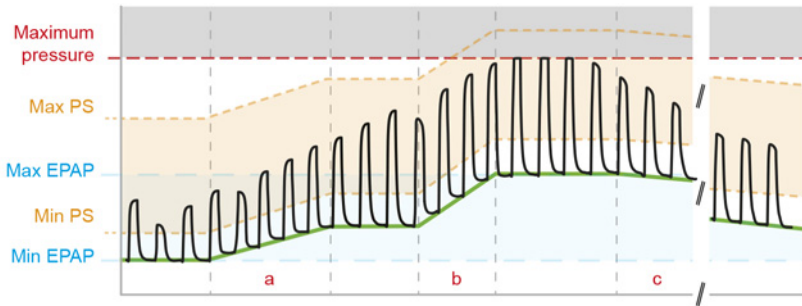

- (a) For flow limitation, EPAP will increase at a maximum rate of 0.5 cm H₂O (0.5 hPa) per breath.
- (b) For obstructive apnoea, EPAP will increase at a rate of approximately 1 cm H₂O (1 hPa) per second on termination of the apnoea.
- (c) EPAP will start to decrease from the first breath after upper airway obstruction has resolved and will continue to decrease slowly until either another upper airway flow limitation/obstruction occurs or Min EPAP is reached.

The AutoEPAP algorithm does not address any other titration target such as lung recruitment to improve oxygenation or offset intrinsic PEEP. Min EPAP should be set to treat lower airway conditions.

Triggering and cycling

S, ST and iVAPS modes only

The device has adjustable trigger/cycle sensitivity to optimise the sensing level according to patient conditions.

Under normal conditions, the device triggers (initiates IPAP) and cycles (terminates IPAP and changes to EPAP) as it senses the change in patient flow. Patient breath detection is enhanced by ResMed's VSync automatic leak management.

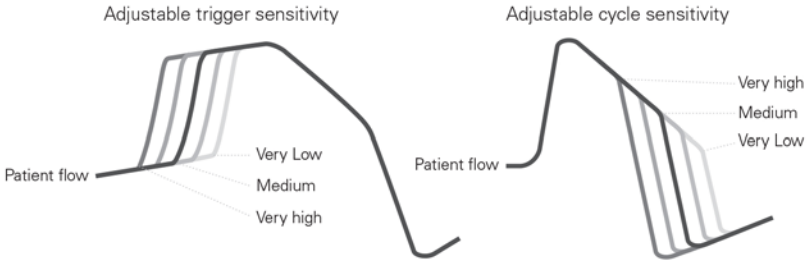

Note: In PAC mode, only Triggering is available.

TiControl - Inspiratory time control

S, ST and iVAPS modes only

Unique to ResMed bilevel devices, TiControl™ allows the clinician to set minimum and maximum limits on the time the device spends in IPAP. The minimum and maximum time limits are set at either side of the patient's ideal spontaneous inspiratory time, providing a 'window of opportunity' for the patient to spontaneously cycle to EPAP.

The minimum time limit is set via the Ti Min parameter and the maximum time limit is set via the Ti Max parameter.

TiControl's Ti Max and Ti Min parameters play a significant role in maximising synchronisation by effectively intervening to limit or prolong the inspiratory time when required. This ensures synchronisation, even in the presence of significant mouth and/or mask leak.

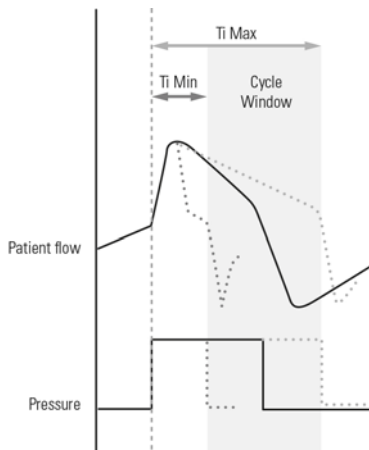

The following table is a guide to selecting the Ti Max and Ti Min values that best correspond to the patient's respiratory rate and inspiration and expiration ratio, depending on the respiratory conditions.

Patient breath (BPM)	Ttot = 60/BPM (sec)	I:E = 1:2 (Reference)	Sufficient inhalation time I:E = 1:1		Secure exhalation time I:E = 1:3
			Ti Min	Ti Max	Ti Max
10	6	2	1.0	2.0	1.5
15	4	1.3	1.0	2.0	1.3
20	3	1.0	0.8	1.5	1.0
25	2.4	0.8	0.7	1.2	0.8
30	2	0.7	0.6	1.0	0.7
35	1.7	0.6	0.5	0.8	0.7
40	1.5	0.5	0.5	0.7	0.7

Rise time adjustment

S, ST, T, PAC and iVAPS modes

Rise Time sets the time taken for the device to reach IPAP. The greater the rise time value, the longer it takes for pressure to increase from EPAP to IPAP.

Patients with a high ventilatory demand may prefer a shorter rise time, while patients who are slow breathers may prefer a longer rise time.

Note: A prolonged rise time inhibits fast pressurisation, therefore, rise time should not be set longer than Ti Min or the patient's normal inspiratory time.

Leak management with VSync

Using ResMed's VSync algorithm, the Lumis device monitors and compensates for leak by continuously and automatically adjusting the baseline flow. This enables reliable delivery of therapy pressure while maintaining patient-device synchrony.

Comfort features

Ramp

Designed to make the beginning of treatment more comfortable, ramp is available in all modes.

In S, ST, T, PAC and iVAPS modes, the EPAP gradually increases from the Start EPAP to the prescribed treatment pressure. Throughout Ramp, Pressure Support is maintained at the same level as that set for treatment.

In iVAPS mode, Pressure Support is maintained at the minimum pressure support (Min PS).

In CPAP mode, the pressure increases from a low pressure (Start Pressure) to the prescribed treatment pressure.

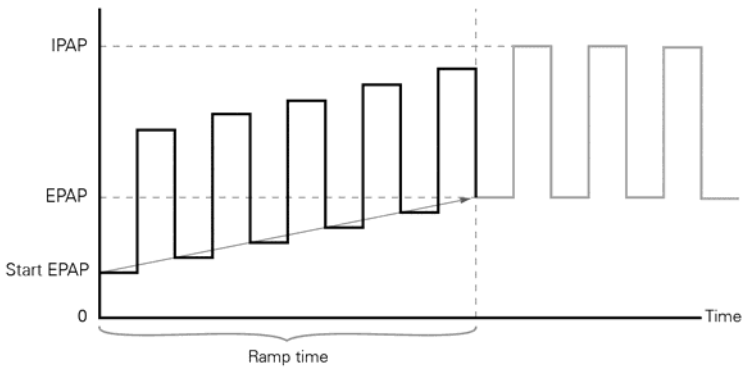

Ramp Down

S, ST, T, PAC and iVAPS modes

When stopping therapy, Ramp Down gives patients the option to gradually reduce pressure support and EPAP, providing a more comfortable transition to spontaneous breathing. Ramp Down gradually decreases the current pressure over a fixed 15 minute period until Start EPAP is reached. The device remains in CPAP mode at Start EPAP until the Start/Stop button is pressed to turn off therapy.

Patient access to Ramp Down is enabled via Essentials Plus.

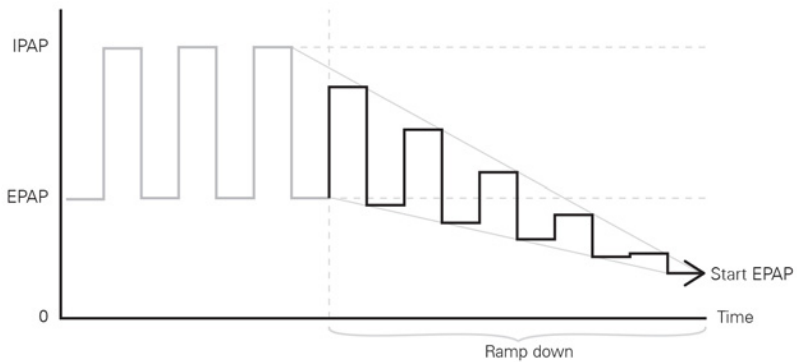

Climate Control

Climate Control is an intelligent system that controls the humidifier and the ClimateLineAir heated air tubing to deliver constant, comfortable temperature and humidity levels during therapy.

Designed to prevent dryness of the nose and mouth, it maintains the set temperature and relative humidity during sleep. Climate Control can be set to either Auto or Manual and is only available when the ClimateLineAir and the HumidAir humidifier are attached.

Climate Control Auto

Climate Control Auto is the recommended and default setting. Climate Control Auto is designed to make therapy as easy as possible, so there is no need to change the temperature or humidity settings.

Climate Control adjusts the humidifier output to maintain a constant, comfortable humidity level of 85% relative humidity while protecting against rainout (water droplets in the air tubing and mask).

Tube Temperature

In Climate Control Auto there is no need to change any settings, but if the air in the mask is too warm or cold for the patient, the tube temperature can be adjusted. The Tube Temperature can be set to anywhere between 16–30°C, or turned off completely.

The temperature sensor located at the mask end of the ClimateLineAir heated air tubing enables the system to automatically control the temperature of the air delivered to the patient. This ensures the temperature of the air delivered to the patient does not fall below the set minimum temperature, therefore maximising breathing comfort for the patient.

Climate Control Manual

Designed to offer more flexibility and control over settings, Climate Control Manual lets the patient adjust the temperature and humidity to the setting which is most comfortable for them.

In Climate Control Manual, the Tube Temperature and the Humidity Level can be set independently however, rainout protection is not guaranteed. If rainout does occur, first try increasing the tube temperature. If the air temperature becomes too warm and rainout continues, try decreasing the humidity.

Humidity Level

The humidifier moistens the air and is designed to make therapy more comfortable. If the patient is getting a dry nose or mouth, turn up the humidity. If the patient is getting moisture in their mask, turn down the humidity.

The Humidity Level can be set to Off or between 1 and 8, where 1 is the lowest humidity setting and 8 is the highest humidity setting.

For each humidifier setting, the Climate Control system delivers a constant amount of water vapour, or absolute humidity (AH), to the patient's upper airway.

Automatic adjustment

The humidifier and ClimateLineAir heated air tubing are controlled by the Climate Control algorithm to deliver constant humidity and temperature outputs. The system adjusts automatically to changes in:

- ambient room temperature and humidity values
- flow due to pressure changes
- flow due to mask or mouth leak.

Setup

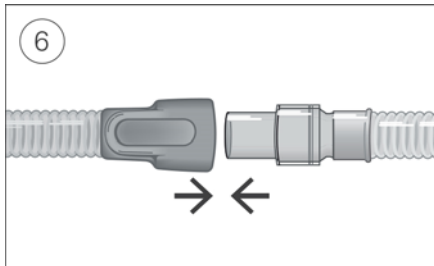
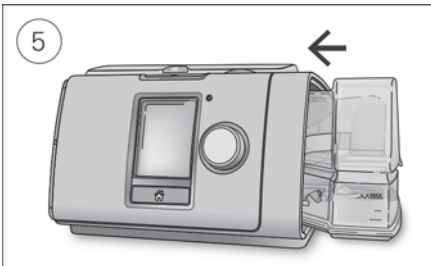
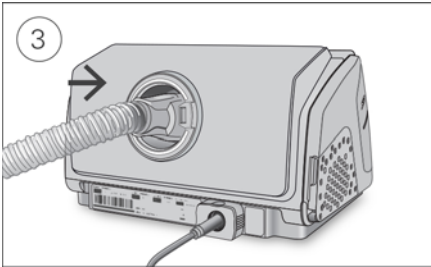
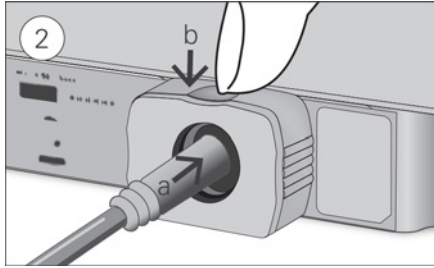
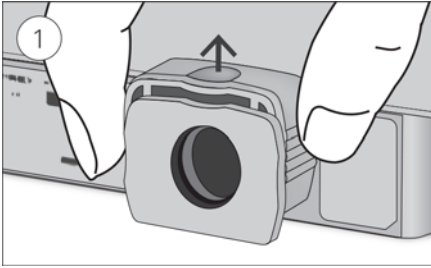

CAUTION

Do not overfill the humidifier as water may enter the device and air tubing.

1. With the device on a stable level surface, grip the retention clip on the back of the device and pull up to open. Note: The retention clip is shown in the open position.
2. (a) Plug the power connector into the device power inlet then (b) push down the retention clip to secure in place. Connect one end of the power cord into the power supply unit and the other end into the power outlet.

3. Connect the air tubing firmly to the air outlet located on the rear of the device.

4. Open the humidifier and fill it with water up to the maximum water level mark.
Do not fill the humidifier with hot water.

5. Close the humidifier and insert it into the side of the device.

6. Connect the free end of the air tubing firmly onto the assembled mask.
See the mask user guide for detailed information.

Recommended masks are available on www.resmed.com.

Note: Ensure the device is placed so that the LED alarm indicator is clearly visible.

Supplemental oxygen

The device is designed to be compatible with supplemental oxygen of up to 4 L/min in iVAPS mode or up to 15 L/min in all other modes.

At a fixed rate of supplemental oxygen flow, the inhaled oxygen concentration will vary depending on the pressure settings, patient breathing pattern, mask selection and the leak rate.

To connect supplemental oxygen to the device you can either connect a ClimateLineAir Oxy or an oxygen connector port. For more information on how to set up the device with supplemental oxygen, refer to the user guide supplied with that accessory.

Notes:

- Adding oxygen may affect the delivered pressure and the accuracy of the displayed leak and minute ventilation.
- Before adding oxygen, familiarise yourself and your patient with the specific warnings relating to the use of supplemental oxygen. These can be found at the end of this guide.

Antibacterial filters

Antibacterial filters increase resistance in the air circuit and may affect accuracy of displayed and delivered pressure, particularly at high flows.

ResMed recommends using an antibacterial filter with a low impedance [eg, 2 cm H₂O (2 hPa) at 60 L/min], such as PALL (BB50T), Air Safety Filter without Luer Port (4222/702) or Air Safety Filter with Side Port 24966 (4222/701). If using the Air Safety Filter with Side Port, an Oxygen Connector Port is required.

Note: When using the SlimLine air tubing above 20 cm H₂O (20 hPa), the device optimum performance may not be reached if used with an antibacterial filter. The device performance must be checked prior to prescribing the SlimLine air tubing for use with an antibacterial filter.

Accessing and exiting the Clinical Menu

You can access, view and set parameters relating to a patient's therapy and device configuration in the Clinical Menu.

To access the Clinical Menu:

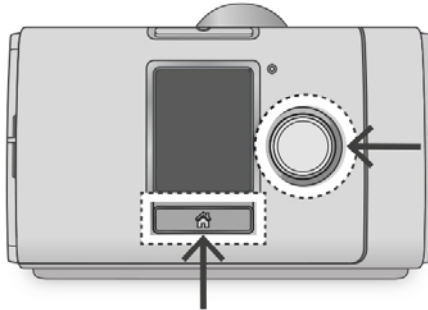

- Press and hold the dial and the Home button for three seconds.
The Home screen is displayed with an unlock icon  in the top right corner of the screen.

To exit the Clinical Menu:

- Press and hold the dial and the Home button for three seconds.
- Select **Exit Clinical Menu** from the Home screen.

The device will automatically exit the Clinical Menu after 20 minutes of inactivity.

Adjusting the clinical settings

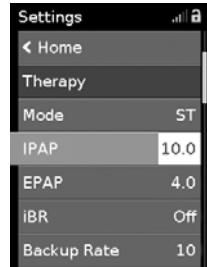
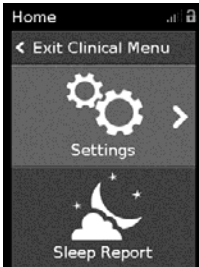

1. Access the Clinical Menu, highlight **Settings** and press the dial.
The **Settings** menu is displayed.
2. Turn the dial to highlight the setting you want to adjust and then press the dial.
3. Turn the dial to adjust the setting and press the dial to save the change.

The settings can be changed in different ways depending on the type of screen:



Turn the dial to edit live in the menu.

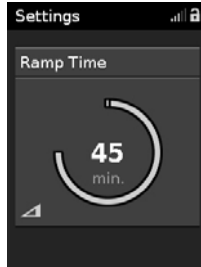

Turn the dial to change the setting.

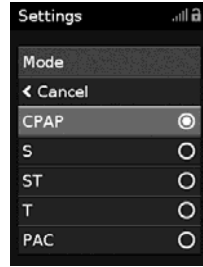

Select from a list of options.

Setting the date and time

Before you set up a new patient and start therapy for the first time, make sure you set the correct local date and time on the device. If you set the date and time after starting therapy, you may lose patient data.

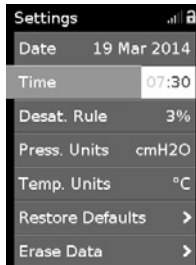

1. In **Settings** menu, select **Date** and change the setting to the correct date.
2. Select **Time** and change it to the correct local time.
3. Make sure the correct local time and date has been applied.

The Lumis settings must be configured for each individual patient. The settings should be periodically reassessed to ensure optimal therapy.

QuickNav

QuickNav is a feature that provides quick navigation between the **Monitoring** screens and the **Settings** menu. Changes can be made to the patient's settings whilst the patient is receiving treatment.

To use QuickNav:

- From the Clinical Menu, press the **Home** button twice to switch back and forth between the **Monitoring** screens and the **Settings** menu.

Settings menu

You set all parameters relating to a patient's therapy and device configuration in the **Settings** menu.

Note: Not all parameters are available in all regions. The default and range values may differ between modes and regions.

The range of parameters in the Settings menu are expressed in cm H₂O, where 1cm H₂O is equal to 0.98 hPa. The units can be changed under Configuration.

Therapy

Parameter	Description	Mode						Range
		S	ST	T	PAC	iVAPS	CPAP	
Mode	Sets the therapy mode available on the device.	✓	✓	✓	✓	✓	✓	
Set Pressure	Sets the fixed treatment pressure.						✓	4–20 cm H ₂ O (4–20 hPa), 0.2 cm H ₂ O (0.2 hPa) increments
IPAP	Sets the pressure to be delivered to the patient when the device is triggered into inspiration.	✓	✓	✓	✓			4–30 cm H ₂ O (4–30 hPa), 0.2 cm H ₂ O (0.2 hPa) increments
EPAP	Sets the pressure to be delivered to the patient when the device is cycled into expiration.	✓	✓	✓	✓	✓		2–[IPAP] cm H ₂ O (2–[IPAP] hPa), 0.2 cm H ₂ O (0.2 hPa) increments
Min PS	Sets the minimum pressure support delivered by the device.						✓	0–20 cm H ₂ O (0–20 hPa), 0.2 cm H ₂ O (0.2 hPa) increments
Max PS	Sets the maximum pressure support in iVAPS mode.						✓	0–28 cm H ₂ O (0–28 hPa), 0.2 cm H ₂ O (0.2 hPa) increments 8–28 cm H ₂ O (8–28 hPa) when AutoEPAP enabled.
Min EPAP	Sets the minimum EPAP (minimum expiratory pressure) delivered by the device. Available when AutoEPAP is enabled.						✓	2–25 cm H ₂ O (2–25 hPa), 0.2 cm H ₂ O (0.2 hPa) increments
Max EPAP	Sets the maximum EPAP delivered by the device. Dependent on Min EPAP. Available when AutoEPAP is enabled.						✓	2–25 cm H ₂ O (2–25 hPa), 0.2 cm H ₂ O (0.2 hPa) increments
AutoEPAP	Enable / disable AutoEPAP.						✓	Off / On

Parameter	Description	Mode						Range
		S	ST	T	PAC	iVAPS	CPAP	
iBR	Enable / disable the intelligent Backup Rate (iBR).		✓			✓		Off / On (ST mode) Always enabled (iVAPS mode)
Resp. Rate	Sets the breaths per minute (BPM).			✓				5-50 BPM
Backup Rate	Sets a fixed backup rate.		✓		✓			5-50 BPM
Target Pt Rate	Sets the rate input for iBR. This should be set at the patient's actual respiratory rate.		✓			✓		8–50 BPM (ST mode) 8–30 BPM (iVAPS mode)
Target Va	Determines the amount of pressure support required by the iVAPS algorithm.					✓		1–30 L/min, 0.1 L/min increments
Ti	Sets the duration of inspiration in timed breath.			✓	✓			0.3–4.0 sec, 0.1 sec increments Dependent on Respiratory Rate.
Ti Max	Set the maximum limit on the time the device spends in IPAP.	✓	✓			✓		0.3–4.0 sec, 0.1 sec increments Dependent on Backup Rate.
Ti Min	Set the minimum limit on the time the device spends in IPAP.	✓	✓			✓		0.1–[Ti Max] sec, 0.1 sec increments Dependent on Ti-Max.
Rise Time	Set the time taken for pressure to increase from EPAP to IPAP. The Rise Time scale can be approximately read as 'milliseconds' (eg, 200 is approximately 200 ms).	✓	✓	✓	✓	✓		Min / 150–900 ms, 50 ms increments Dependent on Ti or Ti Max.
Trigger	Set the level of inspiratory flow above which the device changes from EPAP to IPAP.	✓	✓		✓	✓		Very Low / Low / Med / High / Very High
Cycle	Set the level of inspiratory flow below which the device changes from IPAP to EPAP.	✓	✓			✓		Very Low / Low / Med / High / Very High

Parameter	Description	Mode						Range
		S	ST	T	PAC	iVAPS	CPAP	
Height	Sets the body height needed for the dead space determination.					✓		110–250 cm, 5 cm increments
Mask	Select the type of mask used by the patient. Refer to Mask Device Compatibility List on www.resmed.com .	✓	✓	✓	✓	✓	✓	Full Face / Nasal / Pillows / Pediatric

Comfort

Parameter	Description	Mode						Range
		S	ST	T	PAC	iVAPS	CPAP	
Ramp Time	Set the ramp time.	✓	✓	✓	✓	✓	✓	Off / 5–45 mins
Ramp Down	Enable / disable the Ramp Down feature.	✓	✓	✓	✓	✓		Off / On
Start Pressure	Set the pressure at the start of ramp, up to treatment pressure.						✓	4–Set pressure, 0.2 cm H ₂ O (0.2 hPa) increments
Start EPAP	Set the pressure at the start of ramp, up to minimum treatment pressure.	✓	✓	✓	✓	✓		2–EPAP (or 2–Min EPAP if AutoEPAP is enabled), 0.2 cm H ₂ O (0.2 hPa) increments
Climate Ctrl	Available when HumidAir humidifier is used and ClimateLineAir heated air tubing is connected.	✓	✓	✓	✓	✓	✓	Manual / Auto
Tube Temp.	Set the minimum temperature of air delivered by heated air tubing such as ClimateLineAir.	✓	✓	✓	✓	✓	✓	Off / 60–86°F (16–30°C), 1° increments
Humidity Level	Set the humidity level.	✓	✓	✓	✓	✓	✓	Off / 1–8

Accessories

Parameter	Description	Range
Tube	Select the type of air tubing used by the patient. ClimateLineAir air tubing is automatically detected when connected to the device.	SlimLine / Standard / 3m
AB filter	Select Yes if you attach an antibacterial filter.	No / Yes
Ext. humidifier	Select Yes if you connect an external humidifier.	No / Yes

Parameter	Description	Range
View oximeter	Displayed at all times when an oximeter is connected.	18-300 BPM 0-100% SpO ₂

Alarms

Alarm	Description	Range
High Leak*	Enable / disable the High Leak alarm. Activates when a leak >40 L/min (0.7 L/sec) occurs for >10–30 seconds.	On / Off
Non-Vented Mask	Enable / disable the Non-Vented Mask alarm. Activates within 20–40 seconds when a non-vented mask is attached during therapy. Note: Use of supplemental oxygen with a vented mask may result in false triggering of the Non-Vented Mask alarm.	On / Off
Low MV*	Sets the Low Minute Ventilation alarm. Activates within 20–40 seconds after the measured level remains below the set limit. Note: Alarm may not trigger reliably when using a P10 mask.	Off / 1–10 L/min, 1 L/min increments
Low SpO ₂	Sets the Low SpO ₂ alarm. Activates when the SpO ₂ value is below the set value for 20–40 seconds. Only functional when an oximeter is connected. When the Low SpO ₂ alarm is set, the Oximeter sensor disconnected alarm and Oximeter sensor failure alarm are also enabled.	Off / 70–95%, 1 % increments
Apnoea	Sets the Apnoea alarm. Activates when there is no inspiratory trigger (either patient or machine) detected from the previous inspiration for the set interval. Two consecutive inspirations (either patient or machine triggered) reset the Apnoea alarm.	Off / 10–60 sec, 1 sec increments
Alarm Volume	Sets the alarm volume.	Low / Medium / High

*When enabled, SmartStart is automatically disabled.

Options

Parameter	Description	Range
Essentials	Set the level of access available to the patient.	On / Plus
Leak Alert	Enable / disable the Leak Alert feature. When enabled, leaks >40 L/min (0.7 L/s) for >20 sec result in an audible alert and a high leak message is displayed.	Off / On
Confirm Stop	Enable / disable the Confirm Stop feature. When enabled, if you press Start/Stop during therapy, the Confirm Stop screen will appear. If YES is selected, therapy stops. If NO is selected therapy will continue.	Off / On

Parameter	Description	Range
SmartStart™	Enable / disable the SmartStart feature. If you enable the SmartStart feature, the device will start automatically when the patient breathes into the mask and then stop automatically when the patient removes the mask.	Off / On
Therapy LED	Enable / disable the Therapy LED. When enabled, the Home button will remain illuminated when treatment is in progress.	Off / On
Reminders		
Mask	Set a recurring reminder to the patient to replace the mask.	Off / 1–24 mths, 1 month increments
Humidifier	Set a recurring reminder to the patient to replace the humidifier.	Off / 1–24 mths, 1 month increments
Tube	Set a recurring reminder to the patient to replace the air tubing.	Off / 1–24 mths, 1 month increments
Filter	Set a recurring reminder to the patient to replace the air filter.	Off / 1–24 mths, 1 month increments

Configuration

Parameter	Description	Selection
Language	Set the display language. (Not all languages available in all regions.)	English / Français / Español / Português / Deutsch / Italiano / Nederlands / Svenska / Norsk / Dansk / Suomi / Polski / Türkçe / 简体中文 / 繁體中文
Date	Set the current date. If you set a new date that occurs in the past then an error message is displayed. Before this change can be made, erase the compliance data available under the Configuration menu.	DD Mmm YYYY
Time	Set the current time. If you set a new time that occurs in the past then an error message is displayed. Before this change can be made, erase the compliance data available under the Configuration menu.	24 hours
Press. Units	Set the unit of pressure in which pressure is displayed.	cm H ₂ O / hPa
Desat. Rule	Set the oxygen desaturation threshold in accordance with the AASM criteria.	3% / 4%
Temp. Units	Set the temperature units.	°F / °C
Restore Defaults	Reset to default settings (except for language, date and time).	Yes / No
Erase Data	Erase all data stored on the device and the SD card. Settings, date, time and device run hours are not affected.	Yes / No

Parameter	Description	Selection
About	View Run Hours, SN, SW, provider, type, service and signal strength of the device, CX number, humidifier and internal modem.	

Configuring iVAPS

There are two ways in which you can configure iVAPS mode:

- using Learn Targets—learns the patient’s breathing pattern and calculates the target values automatically, or
- entering the target values manually.

Using Learn Targets

Learn Targets monitors the patient’s resting ventilation, with the goal of learning the patient’s Target Alveolar Ventilation (Target Va) and Target Patient Rate (Target Pt Rate) in preparation for iVAPS mode.

After the final circuit configuration (includes patient’s height, EPAP, appropriate mask or tube settings and any supplemental oxygen added) is achieved, follow the procedure below. The device must be in standby to start the Learn Targets cycle.

During Learn Targets, Tidal Volume and Respiratory Rate are recorded for each breath. Target Va and Target Pt Rate are then calculated after 20 minutes. Ensure the patient remains comfortable, breathing is stable and leak is minimised, particularly in the final five minutes.

Note: iVAPS and AutoEPAP will only be initiated once Learn Target values are accepted.

To use Learn Targets:

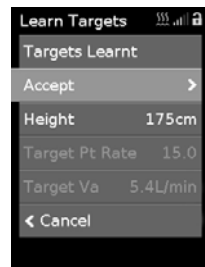

1. In **Settings** menu, select **iVAPS** mode and make any required parameter changes.
2. Select **Learn Targets**. The Learn Targets cycle will begin.
3. If the target values are acceptable, select **Accept** and therapy will commence in iVAPS mode. If target values are not acceptable, select **Cancel** and therapy will terminate.

While Learn Targets is calculating, you can navigate to the **Monitoring** screens and back to **Learn Targets**. You can also exit the Clinical Menu and return later to view the outcome of Learn Targets.

During Learn Targets the device delivers two pressures, EPAP and Pressure Support without backup breath (like S mode). EPAP will be as per the Min EPAP setting if AutoEPAP is On and Pressure Support will be as per the Min PS setting.

Entering the target values manually

The Target Va can also be determined to adopt a Target Pt Rate using a settable Target Va parameter and patient height. Target Pt Rate should be based on the patients normal breathing rate.

To enter target values:

1. In **Settings** menu, in iVAPS mode select **Target Va**.
2. Turn the dial to set the Target Va and press the dial to confirm.
The equivalent MV, Vt and Vt/kg are automatically calculated and displayed and the selected Target Va will now be applied to iVAPS therapy settings.

Working with alarms

The device is fitted with an alarm feature that monitors patient therapy and alerts you to changes that may affect treatment.

If the device has not been properly set up, an alarm may be activated. Check that the power cord, air tubing and mask are all firmly connected.

Adjustable alarms are set via the **Settings** menu.



When an alarm is activated, the yellow LED alarm indicator will flash, the alarm will sound and a message will appear on the screen.

If multiple alarms are activated at the same time, the most recent alarm message will be displayed on the screen and any other activated alarms will be shown in the Alarms list.

Muting activated alarms

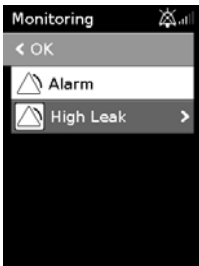

To mute the alarm:

1. Press the dial. A list of activated alarms will appear and the flashing alarm mute icon will be displayed in the top right corner of the screen.
The alarm will be muted for 2 minutes.
2. To return to the previous screen, highlight OK and press the dial.

Once the condition that activated the alarm is corrected, the alarm sound and flashing icon will stop.

If the condition that activated the alarm remains after 2 minutes, the alarm will re-occur.

See the **Alarms troubleshooting** section for help with managing common alarm conditions.

Viewing the alarms

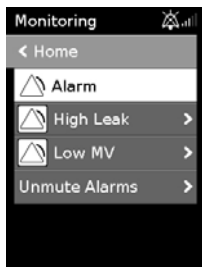

To view the alarm list:

1. From the **Monitoring** screen, turn the dial clockwise until the last **Monitoring** screen is displayed.
2. To view the alarm details, highlight the alarm and press the dial.

Alarm log

When an alarm is activated it is logged on the SD card. Ensure that the SD card is properly inserted into the device.

The alarm log and alarm settings are maintained when the device is powered down and in the event of a power loss. The time of when the power down or power loss occurred is not recorded.

When the alarm log on the device reaches capacity, new alarms will continue to be logged, however, each new alarm will replace the oldest alarm in the log.

Alarm types

All the alarms on the device are classified as medium priority.

Fixed alarms

The alarms pre-set for the device are:

- Power fail
- Blocked tube*
- Tube disconnected
- System fault (system error).

Adjustable alarms

Alarms that can be set are:

- High leak
 - Non-vented mask
 - Low minute ventilation
 - Apnoea
 - Low SpO₂ (when oximeter connected).
-

*Only triggered reliably for pressures above 10 cm H₂O.

The alarms in the above table can also be categorised as:

- Clinical alarms—Low minute ventilation, Apnoea, Low SpO₂
- Patient circuit alarms—Blocked tube, Tube disconnected, High leak, Non-vented mask
- System alarms—Power fail, System fault.

Testing the alarms

The LED alarm indicator will flash and the alarm will sound when power is connected to the device.

The alarms should be tested weekly to ensure they are working correctly. Follow the procedures in this section to test the alarms. When completed, press **Start/Stop** and return the device to the settings appropriate to the patient.

Setup for testing the alarms:

- Turn off all adjustable alarms.
- Set up the device with the air tubing attached, but no mask.
- Set **Ramp** and **SmartStart** to **Off** .

To test the Power fail alarm:

1. Press **Start/Stop**.
2. Lift the retention clip and unplug the power connector from rear of the device. The alarm activates immediately.
3. Plug the power connector back into the device and push down the retention clip. The alarm stops.

To test the Blocked tube alarm:

1. Set pressure above 12 cm H₂O in CPAP mode.
Note: Blocked tube alarm only activates above 10 cm H₂O.
2. Press **Start/Stop**.
3. Block the air tubing with your hand. The alarm activates when tubing is blocked for 120–150 seconds.

To test the Tube disconnect alarm:

1. Disconnect air tubing at the air outlet.
2. Press **Start/Stop**.
The alarm activates after 5–10 seconds.

To test the High leak alarm:

1. Set the High leak alarm to **On**.
2. Leave the open end of the air tubing unblocked.
3. Press **Start/Stop**.
The alarm activates after 10–30 seconds.

To test the Non-vented mask alarm:

1. Attach mask to air tubing.
2. Set the Non-vented mask alarm to **On**.
3. Block the mask vent holes with your hand.
4. Press **Start/Stop**.
The alarm activates after 20–40 seconds.

To test the Low minute ventilation alarm:

1. Set the Low MV alarm to 10 L/min.
2. Press **Start/Stop**.
3. Partially block the open end of the air tubing with your hand keeping MV below 10 L/min.
The alarm activates within 20–40 seconds.

To test the Apnoea alarm:

1. Set the device to CPAP mode.
2. Set the Apnoea Alarm to 10 seconds.
3. Press **Start/Stop**.
4. Partially block the open end of the air tubing with your hand.
The alarm activates within 10–20 seconds.

 **WARNING**

In an environment where multiple devices are in use, the devices may have different alarm settings.

Starting therapy

1. Direct the patient to fit their mask.
2. Direct the patient to press Start/Stop, or if the SmartStart feature is enabled, direct them to breathe into their mask.

You will know that therapy is on when the **Monitoring** screen is displayed.



The pressure bar shows the inspiratory and expiratory pressures in green. The green bar will expand and contract as the patient breathes in and out.

The screen will go black automatically after a short period of time. You can press Home or the dial to turn it back on. If power is interrupted during therapy, the device will automatically restart therapy when power is restored.

The Lumis device has a light sensor that adjusts the screen brightness based on the light in the room.

Stopping therapy

1. Direct the patient to remove the mask.
2. Direct the patient to press Start/Stop, or if SmartStart is enabled, therapy will stop automatically after a few seconds.

Notes:

- If Confirm Stop is enabled, a message is displayed asking if you want to stop therapy. Turn the dial to select **Yes** and then press the dial to stop therapy.
- If Ramp Down is enabled, pressing Start/Stop will initiate Ramp Down.

The **Sleep Report** now provides a summary of the therapy session.

Viewing the Sleep Report

The **Sleep Report** screen shows sleep quality and mask seal status for the most recent therapy session. Turn the dial to scroll down to view more detailed usage data. The parameters displayed will depend on the therapy mode.

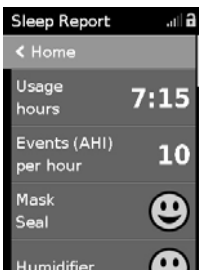

Sleep Report screen parameters

Parameter	Description
Usage hours	Number of hours the device has been used during the last session.
Events (AHI) per hour	Apnoeas and hypopnoeas measured per hour for one day. An apnoea is when the respiratory flow decreases by more than 75% for at least 10 sec. A hypopnoea is when the respiratory flow decreases to 50% for at least 10 sec. The Apnoea Index (AI) and Apnoea-Hypopnoea Index (AHI) are calculated by dividing the total number of events that occurred by the total mask-on therapy period in hours.
Mask Seal	 Good—if the 70 th percentile leak is less than 24 L/min.  Mask needs adjustment.
Humidifier	 Humidifier attached and functional.  Humidifier fault; refer to troubleshooting section.
More Info	
Period	Set the time interval covered by the Sleep Report . The options are: 1 Day / 1 Week / 1 Month / 3 Months / 6 Months / 1 Year
Days Used	Number of days the device has been used during the selected period or since the last compliance data was reset.
Days 4hrs+	Number of days the device has been used for more than 4 hours during the selected period or since the last compliance data was reset.
Avg. Usage	Average number of hours per day the device has been used during the selected period.
Used Hrs	Number of hours the device has been used during the selected period or since the last compliance data reset.
Pressure	Average inspiratory pressure during the selected period (95 th percentile for each day; average of 95 th percentile values for periods >1 day).
Exp. Pressure	Average expiratory pressure during the selected period (95 th percentile for each day; average of 95 th percentile values for periods >1 day).
Leak	Average of the 95 th percentile values of leak during the selected period for days with usage only.
Vt	Average of the 50 th percentile values of tidal volume during the selected period for days with usage only.
RR	Frequency of breathing, expressed as the number of breaths per minute (5-breath moving average).
MV	Average of the 50 th percentile values of minute ventilation during the selected period for days with usage only.
Ti	Duration of inspiration (ie, the respiratory flow into the lungs), expressed in seconds (5-breath moving average).

Parameter	Description
I:E	I:E is the ratio of the inspiratory period to the expiratory period.
Spont Trig	Percentage of breaths that are spontaneously triggered, measured from the last 20 breaths.
Spont Cyc	Percentage of breaths that are spontaneously cycled, measured from the last 20 breaths.
AHI	Apnoea-Hypopnoea Index—average AHI during the selected period. AHI and AI are calculated for times of low leak only.
Total AI	Apnoea Index—average total AI during the selected period.

Cleaning and Maintenance

It is important that the Lumis device is cleaned regularly to ensure optimal therapy. The following sections will help with disassembling, cleaning, checking and reassembling the device.

Disassembling

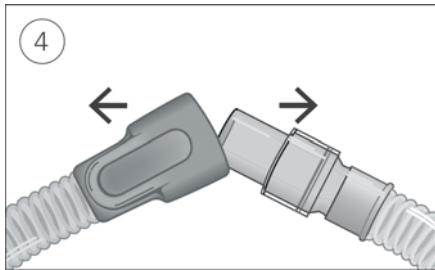
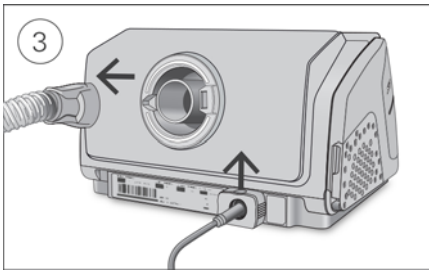
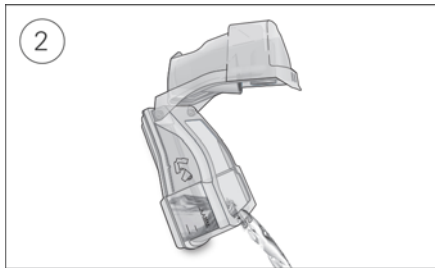
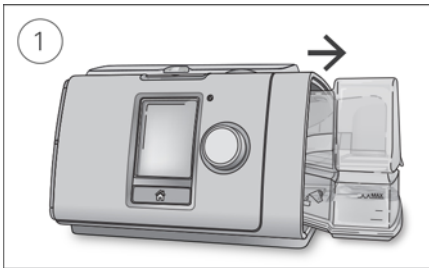

1. Hold the humidifier at the top and bottom, press it gently and pull it away from the device.
2. Open the humidifier and discard any remaining water.
3. Hold the cuff of the air tubing and gently pull it away from the device.
Grip the retention clip and pull up to release the power cord.
4. Hold both the cuff of the air tubing and the swivel of the mask, then gently pull apart.

Cleaning

You should clean the device weekly as described. Refer to the mask user guide for detailed instructions on cleaning the mask.

1. Wash the humidifier and air tubing in warm water using mild detergent.
2. Rinse the humidifier and air tubing thoroughly and allow to dry out of direct sunlight and/or heat.
3. Wipe the exterior of the device with a dry cloth.

Notes:

- The humidifier may be washed in a dishwasher on the delicate or glassware cycle (top shelf only). It should not be washed at temperatures higher than 65°C.
- Do not wash the air tubing in a dishwasher or washing machine.
- Empty the humidifier daily and wipe it thoroughly with a clean, disposable cloth. Allow to dry out of direct sunlight and/or heat.

Checking

You should regularly check the humidifier, air tubing and the air filter for any damage.

1. Check the humidifier:
 - Replace it if it is leaking or has become cracked, cloudy or pitted.
 - Replace it if the seal is cracked or torn.
 - Remove any white powder deposits using a solution of one part household vinegar to 10 parts water.
2. Check the air tubing and replace it if there are any holes, tears or cracks.
3. Check the air filter and replace it at least every six months. Replace more often if there are any holes or blockages by dirt or dust.

To replace the air filter:

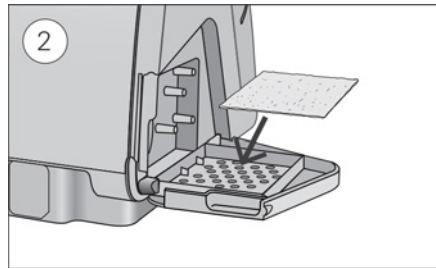
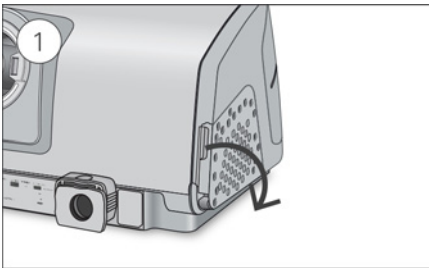

1. Open the air filter cover and remove the old air filter.
The air filter is not washable or reusable.
2. Place a new air filter onto the air filter cover and then close it.
Make sure the air filter is fitted at all times to prevent water and dust from entering the device.

Reassembling

When the humidifier and air tubing are dry, you can reassemble the parts.

1. Connect the air tubing firmly to the air outlet located on the rear of the device.
2. Open the humidifier and fill it with room temperature water up to the maximum water level mark.

3. Close the humidifier and insert it into the side of the device.
4. Connect the free end of the air tubing firmly onto the assembled mask.

Reprocessing

When the device is used for multiple patients, for example, in a sleep lab, clinic, hospital or at a health care provider, the cleanable humidifier, air outlet and air tubing should be reprocessed between each patient use.

If the cleanable humidifier or the air tubing are being used for a single user in the home, refer to the cleaning instructions in this guide or in the User Guide.

Described here are ResMed's recommended and validated procedures for cleaning and disinfecting the cleanable humidifier, air outlet and air tubing. However, the steps for disinfection vary regionally and each healthcare facility should consult its own procedures before carrying out those within this guide.

WARNING

- ResMed cannot give any assurance that deviations from the procedures listed in this guide, and their effect on the performance of the product, will be acceptable.
- When using detergents, disinfectants or sterilisation agents, always follow the manufacturer's instructions.
- Beware of electrocution. Do not immerse the device, power supply or power cord in water. If liquids are spilled into or onto the device, unplug the device and let the parts dry. Always unplug the device before cleaning and make sure that all parts are dry before plugging it back in.

Surface disinfection

1. Wipe the exterior of the device including display, externally accessible ports, side cover, power supply unit and accessories with a disposable cloth and mild detergent or alcohol disinfectant (see list below).
2. Remove any excess disinfectant with a disposable dry cloth.

Agents recommended for surface disinfection and cleaning:

- Warm water and mild detergent eg, Teepol™ multipurpose detergent
- Window cleaner or other premixed surface detergent
- Methyl alcohol solution
- 70% Ethyl alcohol solution
- 70-90% Isopropanol solution
- 10% Bleach solution
- Isopropyl wipes
- CaviCide™
- Mikrozid®
- Actichlor™ Plus
- Terralin®.

Note: Agents may not be available in all regions.

Reprocessing the air tubing and Air10 tubing elbow

Disconnecting

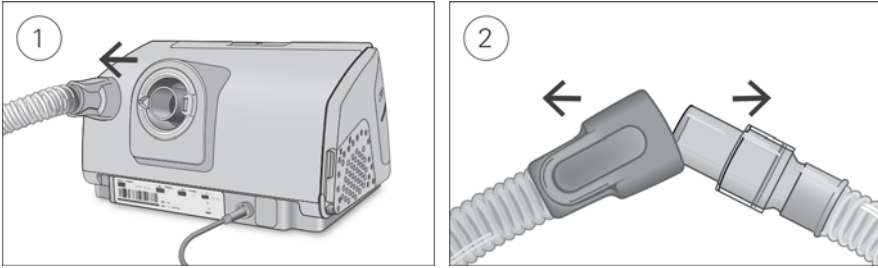

1. Hold the cuff of the air tubing and gently pull it away from the device.
2. Hold both the cuff of the air tubing and the swivel of the mask, then gently pull apart.

Decontaminating

Before the disinfection process, each component must be cleaned and rinsed so no visible contamination is present.

1. Clean all components with a soft bristled brush for one minute while soaking in detergent solution (see table below). Pay particular attention to all crevices and cavities.
2. Run the detergent solution through the air tubing repeatedly until no contamination is visible.
3. Thoroughly rinse each component according to the detergent manufacturer's instructions.

ResMed has tested the following detergents according to the manufacturer's instructions:

Detergent	Water temperature	SlimLine / Standard	ClimateLineAir	ClimateLineAir Oxy	Air10 tubing elbow
Alconox™ (diluted at 1%)	Hot water (approx or 60°C) Warm water (approx 45 to 60°C) Room temperature water (approx 21°C)	✓	✓	✓	✓
Neodisher MediZym™ (diluted at 2.0%)	Warm water (approx 45 to 60°C)	✓			
Gigazyme® (diluted at 1.0%)	Room temperature water (approx 21°C)		✓		✓

Disinfecting

In the procedures below, only one disinfection process needs to be performed.

High level thermal

Part	Validated number of cycles		
	Hot water: 75°C for 30 minutes OR 70°C for 100 minutes.		
SlimLine	20		
ClimateLineAir	26		
ClimateLineAir Oxy	20		
Standard	100		
Air10 tubing elbow	26		

1. Immerse the air tubing in a water bath.
Take care that no air bubbles are trapped inside the air tubing.
2. Increase the water bath temperature to 70°C for 100 minutes, or a maximum of 75°C for 30 minutes. Higher temperatures may damage the tubing.
3. Air dry out of direct sunlight and/or heat.

High level chemical

Part	Validated number of cycles		
	CIDEX® OPA Ortho-phthalaldehyde 0.55% for 12 minutes	Sterrad NX Sterrad 100S	Gigasept FF® 5% for 15 minutes
SlimLine	100	–	–
ClimateLineAir	26	26	26
ClimateLineAir Oxy	20	20	–
Standard	100	–	–
Air10 tubing elbow	26	–	26

1. Soak the air tubing/Air10 tubing elbow in a commercially available solution of a chemical sterilant.
Take care that no air bubbles are trapped inside the air tubing.
2. Thoroughly rinse the air tubing/Air10 tubing elbow in drinking quality water (five litres per assembly) by immersing it completely for a minimum of one minute in duration.
3. Repeat the rinse procedure two additional times using fresh water for a total of three rinses.
4. Air dry out of direct sunlight and/or heat.

Inspecting

Perform a visual inspection of the components. If any visible deterioration is apparent (holes, tears or cracks etc), the components should be discarded and replaced. Slight discoloration may occur and is acceptable.

Reconnecting the air tubing

When the air tubing is dry, you can reconnect it to the device.

1. Connect the air tubing firmly to the air outlet located on the rear of the device.
2. Connect the free end of the air tubing firmly onto the assembled mask.

Packaging and storage

Store in a dry, dust-free environment away from direct sunlight.

Storage temperature: 20°C to 60°C.

Reprocessing the humidifier and air outlet

Disassembling

The following instructions provide guidance on how to correctly disassemble the cleanable humidifier and the air outlet.

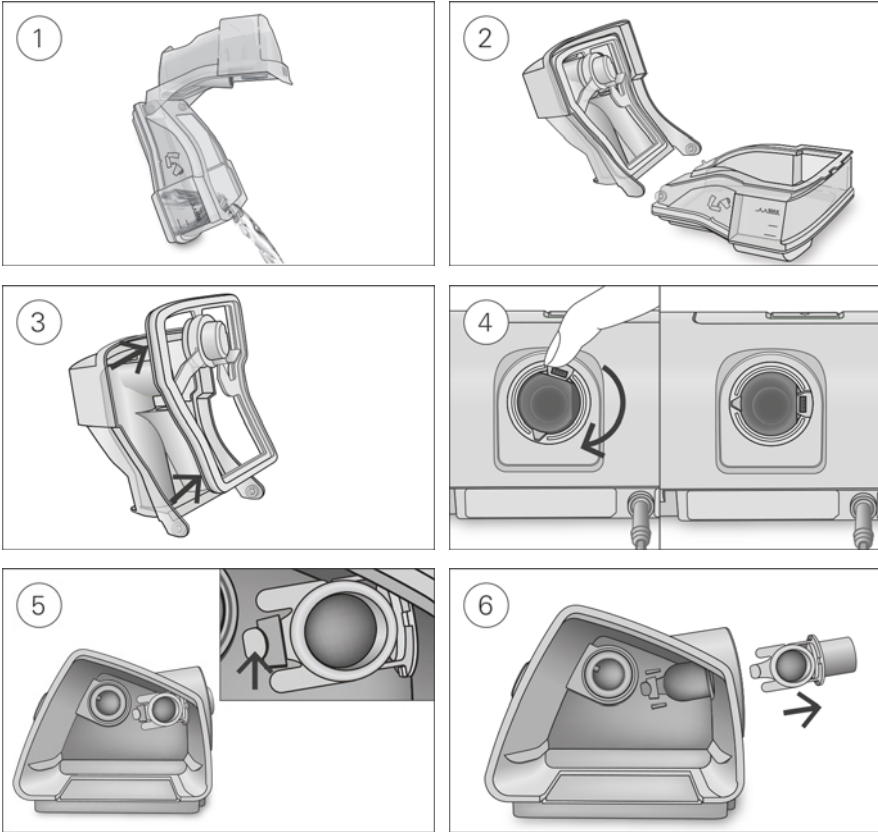

1. Remove the humidifier from the device, open it and discard any remaining water.
2. Hold the humidifier base and then fully open the humidifier lid and pull it away so that it easily detaches from the base.
3. Remove the humidifier seal from the humidifier lid by pulling it away.
4. Align the swivel so that the connector port is on the right. If the swivel is not in this position you will not be able to remove the air outlet.
5. Locate the air outlet on the inside of the device and release it by pressing the clip firmly.
6. Remove the air outlet by pulling it out through the air outlet socket at the rear of the device.

Decontaminating

Before the disinfection process, each component must be cleaned and rinsed so no visible contamination is present.

1. Clean all components with a soft bristled brush for one minute while soaking in detergent solution (see table below). Pay particular attention to all crevices and cavities.
2. Thoroughly rinse each component according to the detergent manufacturer's instructions.

ResMed has tested the following detergents according to the manufacturer's instructions:

Detergent	Water temperature	Cleanable humidifier	Air outlet
Alconox (diluted at 1%)	Hot water (approx 60°C) Warm water (approx 45 to 60°C) Room temperature water (approx 21°C)	✓	✓
Gigazyme (diluted at 1.0%)	Room temperature water (approx 21°C)	✓	✓

Disinfecting

In the procedures below, only one disinfection process needs to be performed.

High level thermal

Part	Validated number of cycles
	Hot water: 90°C for 1 minute OR 75°C for 30 minutes OR 70°C for 100 minutes. Due to specific regional requirements, ResMed cleanable humidifiers have been tested for disinfection (100 cycles) at 93°C for 10 minutes
Cleanable humidifier	130
Air outlet	130

1. Soak the disassembled components in a hot water bath at pasteurizing temperature. Take care that no air bubbles are trapped against the components.
2. Air dry out of direct sunlight and/or heat.

High level chemical

Part	Validated number of cycles
	CIDEX OPA Ortho-phthalaldehyde 0.55% for 12 minutes Gigasept FF 5% for 15 minutes Sterrad NX Sterrad 100S
Cleanable humidifier	130
Air outlet	130

1. Soak the disassembled components in a commercially available solution of a chemical sterilant. Take care that no air bubbles are trapped against the components.
2. Thoroughly rinse the cleanable humidifier in drinking quality water (five litres per assembly) by immersing it completely for a minimum of one minute in duration.
3. Repeat the rinse procedure two additional times using fresh water for a total of three rinses.
4. Air dry out of direct sunlight and/or heat.

Inspecting

Perform a visual inspection of all components. If any visible deterioration is apparent (cracking, crazing, tears, etc), the humidifier should be discarded and replaced. Slight discoloration of the silicone components may occur and is acceptable.

Reassembling

The following instructions provide guidance on how to correctly reassemble the air outlet and the humidifier.

To reassemble the air outlet

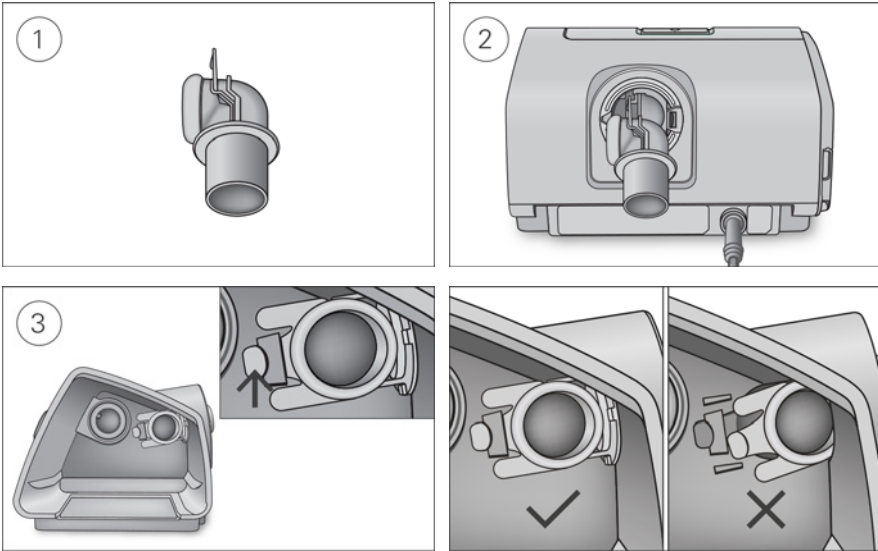

1. Hold the air outlet with the seal pointing to the left and the clip pointing forward.
2. Make sure that the air outlet is correctly aligned and insert the air outlet into the socket. It will click in place.
3. Check if the air outlet is inserted correctly as shown.

To insert the humidifier seal:

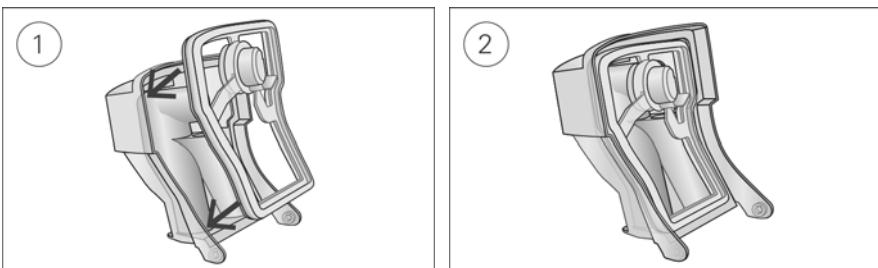

1. Place the seal into the lid.
2. Press down along all edges of the seal until it is firmly in place.

To reassemble the humidifier lid:

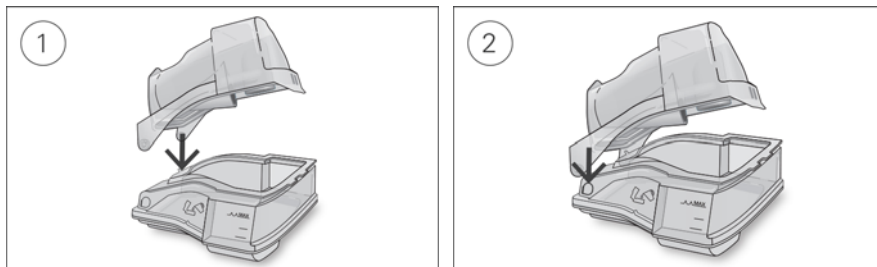

1. Insert one side of the lid into the pivot hole of the base.
2. Slide the other side down the ridge until it clicks into place.

Packaging and storage

Store in a dry, dust-free environment away from direct sunlight.

Storage temperature: -20°C to 60°C.

Data management and therapy compliance

For therapy management, the Lumis device stores patient therapy data on the device and has the ability to transfer it remotely to the care provider. Data can then be accessed via ResMed's AirView™ therapy management solution.

The Lumis device also stores data on the SD card. This data can be transferred via an SD Card Reader to ResMed's ResScan™ therapy management system.

For more information on therapy management with AirView or ResScan, refer to the manuals supplied with the software.

Remote monitoring

The Lumis device has wireless communication which has the ability to automatically transmit summary and detailed data on a regular basis. It also allows you to change settings remotely.

The Wireless signal strength icon  displayed at the top right of the screen indicates the signal strength. Advise the patient to check the signal strength on their device.

Notes:

- Therapy data might not be transmitted if used outside of the country or region of purchase.
- Devices with wireless communication might not be available in all regions.

SD card

Every Lumis device comes with an SD card already inserted and ready to be used. Once the data is loaded into ResScan or AirView via the SD Card Reader, you can review and analyse data, as well as update therapy settings and transfer them to the patient's device via the SD card.

To remove the SD card:

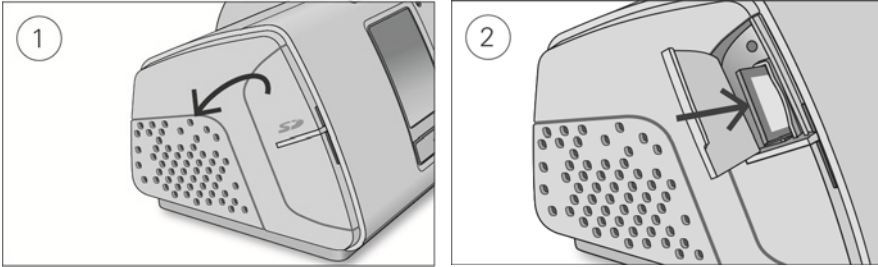

1. Open the SD card cover.
2. Push in the SD card to release it. Remove the SD card from the device.

Do not remove the SD card from the device when the SD light is flashing.

To insert the SD card:

1. Open the SD card cover.
2. Push the SD card into the device until it clicks.
The following message is briefly displayed: **Preparing SD card, do not remove power or your card.**

Data storage

The Lumis device stores summary data such as AHI, Total Hours Used and Leak. Detailed data such as respiratory rate and tidal volume are stored on the SD card and can be viewed with AirView and ResScan. High resolution flow and pressure data are stored on the SD card.

Data can be transmitted to therapy management software either remotely via wireless communication, or via SD card. The different ways of transmitting data are detailed in the table below.

For more information on therapy management with AirView or ResScan, refer to the manuals supplied with the software.

Type of data	Transmission method			Sessions stored
	Wireless communication to AirView	SD card to ResScan	SD Card to AirView (card-to-cloud)	
Summary data (compliance data)	✓	✓	✓	365
Detailed data	✓	✓	✓	
High resolution flow and pressure data (25 Hz - every 40 ms)		✓		Limited by usage and SD card storage capacity
Alarm log		✓		

Detailed data are stored on the SD card and can be viewed via ResScan or AirView. Examples of detailed data available are shown below.

Detailed data

Parameter	Sampling rate	
	ResScan	AirView
Apnoea or hypopnoea events	aperiodic	aperiodic
Flow limitation (flat to round)	1/2 Hz (2 sec)	1 min
Leak (L/sec)	1/2 Hz (2 sec)	1 min
Tidal volume (mL)	1/2 Hz (2 sec)	1 min
Pressure (cm H ₂ O / hPa)	1/2 Hz (2 sec)	1 min
Respiratory rate (BPM)	1/2 Hz (2 sec)	1 min
Pulse rate (beats/min)—if an oximeter adapter is attached	1 Hz (1 sec)	1 min
Spontaneous trigger and cycle	1/2 Hz (2 sec)	1 min
Oxygen saturation (SpO ₂)—if an oximeter adapter is attached	1 Hz (1 sec)	1 min

Software upgrade

The device has a software upgrade feature. When a software upgrade is in progress, the screen will flash for approximately 10 minutes.

Managing patient care

The following section has been provided to assist you with managing your patients' care.

Patient menu

In the patient menu there are two types of access levels, Essentials and Essentials Plus.

Essentials is designed to make the device interaction and menu navigation easier for patients. It is a simple choice for patients who do not want to worry about settings or menu navigation. It provides access to the most important comfort features such as Ramp Time, Humidity Level (if humidifier available) and Run Mask Fit.

However, by enabling Essentials Plus you can allow highly engaged patients to access additional features for control over more of their therapy settings, including changing their mask type, Ramp Down, SmartStart and Run Warmup (if humidifier available).

Essentials Plus can be enabled via the Settings menu. For more information on the patient menu, see the User Guide.

Therapy data

If you wish to use wireless communication, advise patients to check the Wireless signal strength icon  once they have the device set up at home. The icon will indicate the strength of coverage by the number of bars displayed—the higher the number of bars, the stronger the signal.

Travelling

Patients can take their Lumis device wherever they go. Advise patients of the following:

- Use the travel bag provided to prevent damage to the device.
- Empty the humidifier and pack it separately in the travel bag.

- Make sure the patient has the appropriate power cord for the region of travel. For information on purchasing, contact your ResMed representative.
- When using an external battery, turn off the humidifier in order to maximise battery life. Do this by turning the **Humidity Level** to Off.

Travelling by plane

The Lumis device may be taken on board as carry-on luggage. Medical devices do not count toward the carry-on luggage limit.

The Lumis device can be used on a plane as it meets the Federal Aviation Administration (FAA) requirements. Air travel compliance letters can be downloaded and printed from www.resmed.com.

When using the device on a plane:

- Make sure the humidifier is completely empty and inserted into the device. The device will not work without the humidifier inserted.
- Turn on **Airplane Mode** (for instructions refer to the User Guide).

CAUTION





Do not use the device with water in the humidifier on a plane due to the risk of inhalation of water during turbulence.

Troubleshooting

If there is a problem, try the following suggestions. If you are not able to fix the problem, contact your local ResMed dealer or ResMed office. Do not open the device.

General troubleshooting

Problem/possible cause	Solution
Air is leaking from around the mask	
Mask may be fitted incorrectly.	Make sure the mask is fitted correctly. See mask user guide for fitting instructions or use the Mask Fit function to check mask fit and seal.
The patient is getting a dry or blocked nose	
Humidity level may be set too low.	Adjust the Humidity Level. If you have ClimateLineAir heated air tubing, see the ClimateLineAir user guide.
There are droplets of water in the mask and air tubing	
Humidity level may be set too high.	Adjust the Humidity Level. If you have ClimateLineAir heated air tubing, see the ClimateLineAir user guide.
The patient is getting a very dry mouth	
Air may be escaping through the patient's mouth.	Increase the Humidity Level. The patient may need a chin strap to keep the mouth closed or a full face mask.
The patient feels that too much air is being delivered from the device	
Ramp may be turned off.	Use the Ramp Time option.



Problem/possible cause	Solution
The patient feels that not enough air is being delivered from the device	
Ramp may be in progress 	Wait for air pressure to build up or turn Ramp Time off.
Ramp Down may be in progress 	Press Start/Stop to stop therapy then press Start/Stop to restart and continue therapy.
Non-vented mask is used.	Only use a vented mask.
Mask vents may be blocked	Make sure there is sufficient venting. Unblock mask vents if necessary.
A low EPAP in conjunction with supplemental oxygen may result in false triggering of this alarm on a vented mask.	Increase EPAP.
No display	
Backlight on the screen may have turned off. It turns off automatically after a short period of time.	Press Home or the dial to turn it back on.
Power may not be connected.	Connect the power supply and make sure the plug is fully inserted. Note: the retention clip should be in the open position when inserting the plug. For instructions refer to the Setup section.
Therapy has stopped, but the device is still blowing air	
Device is cooling down.	Device blows a small amount of air in order to avoid condensation in the air tubing. It will stop automatically after 20 minutes.
Humidifier is leaking	
Humidifier may not be assembled correctly.	Check for damage and reassemble the humidifier correctly.
Humidifier may be damaged or cracked.	Replace the humidifier.
Sleep report for the humidifier indicates 	
Humidifier fault	Contact your local ResMed dealer or ResMed office.
The patient's therapy data has not been transmitted	
Wireless coverage may be poor.	Advise the patient to place the device where there is coverage (ie, on their bedside table, not in a drawer or on the floor). The Wireless signal strength icon  indicates good coverage when all bars are displayed, and poor coverage when fewer bars are displayed.
The No wireless connection icon  is displayed on the top right of the screen. No wireless network available.	Advise the patient that therapy data can be sent using the SD Card.
Device may be in Airplane Mode.	Turn off Airplane Mode, see Travelling by plane.

Problem/possible cause	Solution
SmartStart is enabled, but the device does not automatically start when the patient breathes into their mask	
Breath is not deep enough to trigger SmartStart.	To start therapy, take a deep breath in and out through the mask, before breathing normally. Press Start.
There is excessive leak.	Adjust the mask and headgear. Air tubing may not be connected properly. Connect firmly at both ends.

SmartStart is enabled, but the device does not automatically stop when the patient removes their mask

Incompatible mask being used.	Only use equipment recommended by ResMed. Contact ResMed or see www.resmed.com for more information. If the patient is using a nasal pillows mask with set pressure less than 7 cm H ₂ O (7 hPa), SmartStart will not work and should be disabled.
A pediatric mask with a set pressure less than 8 cm H ₂ O (8 hPa) is used.	Disable SmartStart.

Displays message: Read only card, please remove, unlock and re-insert SD card

SD card switch may be in the lock (read-only) position.	Move the switch on the SD Card from the lock position  to the unlock position  and then re-insert it.
---	--

Displays message: Date and time can not be set in the past

Date and time were not set before data was recorded.	Select Erase Data in Settings . Once the data is erased, set the correct local date and time.
--	--

Alarms troubleshooting

The information listed below is based on having the appropriate alarm settings for the patient's therapy. When an adjustable alarm is activated, re-confirm the alarm settings.

Problem/possible cause	Solution
Display disappears and an alarm is activated	
Power failure.	Remove the patient's mask and turn off supplemental oxygen (if applicable) until power is restored.
Power cord is disconnected or mains power has been turned off during therapy.	Ensure the power cord is connected and the mains power switch (if available) is on.
Displays message: High leak detected, check your water tub, tub seal or side cover	
Humidifier may not be inserted properly.	Make sure the humidifier is correctly inserted.
Humidifier seal may not be inserted properly.	Open the humidifier and make sure that the seal is correctly inserted.

Problem/possible cause	Solution
Displays message: High leak detected, connect your tubing	
Air tubing may not be connected properly.	Make sure the air tubing is firmly connected at both ends.
Mask may be fitted incorrectly.	Make sure the mask is fitted correctly. See mask user guide for fitting instructions or use the Mask Fit function to check mask fit and seal.
Displays message: Tubing blocked, check your tubing	
Air tubing may be blocked.	Check the air tubing and remove any blockages. Press the dial to clear the message and then press Start/Stop to restart the device.
Displays message: Leak detected, check your system setup and all connections	
Mask may be fitted incorrectly.	Make sure the mask is fitted correctly. See mask user guide for fitting instructions or use the Mask Fit function to check mask fit and seal.
Displays message: No SpO2 data, check your oxi sensor attachment to module/finger	
Oximeter sensor is not attached properly.	Ensure that the oximeter sensor is attached properly to the module and the patient's finger.
Oximeter sensor may be faulty.	If the message appears repeatedly, the oximeter sensor might be faulty. Replace the oximeter.
Displays message: Non-vented mask detected, use vented mask or unblock your mask vents	
Non-vented mask is used.	Only use a vented mask.
Mask vents may be blocked	Make sure there is sufficient venting. Unblock mask vents if necessary.
A low EPAP in conjunction with supplemental oxygen may result in false triggering of this alarm on a vented mask.	Increase EPAP.
Displays message: System fault, refer to user guide, Error 004	
Device may have been left in a hot environment.	Allow to cool before re-use. Disconnect the power supply and then reconnect it to restart the device.
Air filter may be blocked.	Check the air filter and replace it if there are any blockages. Disconnect the power supply and then reconnect it to restart the device.
Air tubing may be blocked.	Check the air tubing and remove any blockages. Press the dial to clear the message and then press Start/Stop to restart the device.
There may be water in the air tubing.	Empty the water from the air tubing. Disconnect the power supply and then reconnect it to restart the device.

Problem/possible cause	Solution
Displays message: System fault, refer to user guide, Error 022	
Power cord may not be correctly inserted into the device.	Remove the power cord from the device and then re-insert it. Ensure that the power cord is fully inserted into the device. Note: the retention clip should be in the open position when inserting the plug. For instructions refer to the Setup section. If the problem continues, contact your local ResMed dealer or ResMed office. Do not open the device.
All other error messages, for example, System fault, refer to user guide, Error OXX	
An unrecoverable error has occurred on the device.	Contact your local ResMed dealer or ResMed office. Do not open the device.

General warnings and cautions

WARNING

- Make sure that you arrange the air tubing so that it will not twist around the head or neck.
- Make sure the power cord and plug are in good condition and the equipment is not damaged.
- Keep the power cord away from hot surfaces.
- If you notice any unexplained changes in the performance of the device, if it is making unusual sounds, if the device or the power supply are dropped or mishandled, or if the enclosure is broken, discontinue use and contact your care provider or your ResMed Service Centre.
- Do not open or modify the device. There are no user serviceable parts inside. Repairs and servicing should only be performed by an authorised ResMed service agent.
- Beware of electrocution. Do not immerse the device, power supply or power cord in water. If liquids are spilled into or onto the device, unplug the device and let the parts dry. Always unplug the device before cleaning and make sure that all parts are dry before plugging it back in.
- Supplemental oxygen must not be used while smoking or in the presence of an open flame.
- Always make sure that the device is turned on and airflow generated before the oxygen supply is turned on. Always turn the oxygen supply off before the device is turned off, so that unused oxygen does not accumulate within the device enclosure and create a risk of fire.
- Do not perform any maintenance tasks while the device is in operation.
- The device should not be used adjacent to or stacked with other equipment. If adjacent or stacked use is necessary, the device should be observed to verify normal operation in the configuration in which it will be used.
- The use of accessories other than those specified for the device is not recommended. They may result in increased emissions or decreased immunity of the device.
- Regularly check the antibacterial filter for signs of moisture or other contaminants, particularly during nebulisation or humidification. Failure to do so could result in increased breathing system resistance.

CAUTION

- Use only ResMed parts and accessories with the device. Non-ResMed parts may reduce the effectiveness of the treatment and/or damage the device.

- Use only vented masks recommended by ResMed or by the prescribing doctor with this device. Fitting the mask without the device blowing air can result in rebreathing of exhaled air. Make sure that the mask vent holes are kept clear and unblocked to maintain the flow of the fresh air into the mask.
- Be careful not to place the device where it can be bumped or where someone is likely to trip over the power cord.
- Blocking the air tubing and/or air inlet of the device while in operation could lead to overheating of the device.
- Keep the area around the device dry, clean and clear of anything (eg, clothes or bedding) that could block the air inlet or cover the power supply unit.
- Do not place the device on its side as water might get into the device.
- Incorrect system setup may result in incorrect mask pressure reading. Ensure the system is correctly set up.
- Do not use bleach, chlorine, alcohol, or aromatic-based solutions, moisturising or antibacterial soaps or scented oils to clean the device, the humidifier or air tubing. These solutions may cause damage or affect the humidifier performance and reduce the life of the products.
- If you use the humidifier, always place the device on a level surface lower than the patient's head to prevent the mask and air tubing from filling with water.
- Do not overfill the humidifier as water may enter the device and air tubing.
- Leave the humidifier to cool for ten minutes before handling to allow the water to cool and to make sure that the humidifier is not too hot to touch.
- Make sure that the humidifier is empty before transporting the device.

Technical specifications

Units are expressed in cm H₂O and hPa. 1 cm H₂O is equal to 0.98 hPa.

90W power supply unit

AC input range:	100–240V, 50–60Hz 1.0–1.5A, Class II 115V, 400Hz 1.5A, Class II (nominal for aircraft use)
DC output:	24V $\frac{---}{---}$ 3.75A
Typical power consumption:	53W (57VA)
Peak power consumption:	104W (108VA)

Environmental conditions

Operating temperature:	+5°C to +35°C Note: The air flow for breathing produced by this therapy device can be higher than the temperature of the room. Under extreme ambient temperature conditions (40°C) the device remains safe.
Operating humidity:	10 to 95% relative humidity, non-condensing
Operating altitude:	Sea level to 2,591 m; air pressure range 1013 hPa to 738 hPa
Storage and transport temperature:	-20°C to +60°C
Storage and transport humidity:	5 to 95% relative humidity, non-condensing

Electromagnetic compatibility

The Lumis complies with all applicable electromagnetic compatibility requirements (EMC) according to IEC 60601-1-2:2014, for residential, commercial and light industry environments. It is recommended that mobile communication devices are kept at least 1 m away from the device.

Information regarding the electromagnetic emissions and immunity of this ResMed device can be found on www.resmed.com, on the Products page under Service and Support.

EN 60601-1:2006 classification

Class II (double insulation), Type BF, Ingress protection IP22.

Sensors

Pressure sensors: Internally located at device outlet, analogue gauge pressure type, -5 to +45 cm H₂O (-5 to +45 hPa)

Flow sensor: Internally located at device inlet, digital mass flow type, -70 to +180 L/min

Maximum single fault steady pressure

Device will shut down in the presence of a single fault if the steady state pressure exceeds: 30 cm H₂O (30 hPa) for more than 6 sec or 40 cm H₂O (40 hPa) for more than 1 sec.

Sound

Pressure level measured according to ISO 80601-2-70:2015 (CPAP mode):

SlimLine: 27 dBA with uncertainty of 2 dBA

Standard: 27 dBA with uncertainty of 2 dBA

SlimLine or Standard and humidification: 30 dBA with uncertainty of 2 dBA

Power level measured according to ISO 80601-2-70:2015 (CPAP mode):

SlimLine: 35 dBA with uncertainty of 2 dBA

Standard: 35 dBA with uncertainty of 2 dBA

SlimLine or Standard and humidification: 38 dBA with uncertainty of 2 dBA

Declared dual-number noise emission values in accordance with ISO 4871:1996.

Alarm volume settings

Low (nominal 54 dBA), Medium (nominal 60 dBA), High (nominal 73 dBA)

Physical - device and humidifier

Dimensions (H x W x D): 116 mm x 255 mm x 150 mm

Air outlet (complies with ISO 5356-1:2004): 22 mm

Weight (device and cleanable humidifier): 1336 g

Housing construction: Flame retardant engineering thermoplastic

Water capacity: To maximum fill line 380 mL

Cleanable humidifier - material: Injection moulded plastic, stainless steel and silicone seal

Temperature

Maximum heater plate: 68°C

Cut-out: 74°C

Maximum gas temperature: ≤ 41°C

Air filter

Standard: Material: Polyester non woven fibre
Average arrestance: >75% for ~7 micron dust

Hypoallergenic: Material: Acrylic and polypropylene fibres in a polypropylene carrier
Efficiency: >98% for ~7-8 micron dust; >80% for ~0.5 micron dust

Aircraft use

ResMed confirms that device meets the Federal Aviation Administration (FAA) requirements (RTCA/DO-160, section 21, category M) for all phases of air travel.

Wireless module

Technology used: 2G GSM

It is recommended that the device is a minimum distance of 2 cm from the body during operation. Not applicable to masks, tubes or accessories

Declaration of Conformity (DoC to the R&TTE Directive)

ResMed declares that the Lumis device is in compliance with the essential requirements and other relevant provisions of Directive 1999/5/EC. A copy of the declaration of conformity (DoC) can be found on www.ResMed.com/ProductSupport.

Operating pressure range

S, ST, T, PAC, iVAPS: 2 to 30 cm H₂O (2 to 30 hPa)
CPAP 4 to 20 cm H₂O (4 to 20 hPa)

Supplemental oxygen

Maximum flow: 15 L/min (S, ST, T, PAC, CPAP), 4 L/min (iVAPS)

Pneumatic flow path

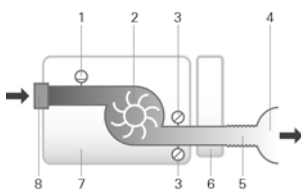

1. Flow sensor
2. Blower
3. Pressure sensor
4. Mask
5. Air tubing
6. Humidifier
7. Device
8. Inlet filter

Design life

Device, power supply unit: 5 years
Cleanable humidifier: 2.5 years
Air tubing: 6 months

Operator position

The device is designed to be operated within arm's length. An operator should position their line of sight within an angle of 30 degrees from a plane perpendicular to the screen.

Humidifier performance

Mask Pressure cm H ₂ O (hPa)	Nominal RH output %		Nominal system output AH ¹ , BTPS ²	
	Setting 4	Setting 8	Setting 4	Setting 8
3	85	100	6	>10
4	85	100	6	>10
10	85	100	6	>10
20	85	90	6	>10
25	85	90	6	>10
30	85	90	6	>10

¹ AH - Absolute Humidity in mg/L

² BTPS - Body Temperature Pressure Saturated

Air tubing

Air tubing	Material	Length	Inner diameter
ClimateLineAir	Flexible plastic and electrical components	2 m	15 mm
ClimateLineAir Oxy	Flexible plastic and electrical components	1.9 m	19 mm
SlimLine	Flexible plastic	1.8 m	15 mm
Standard	Flexible plastic	2 m	19 mm
3 m	Flexible plastic	3 m	19 mm

Heated air tubing temperature cut-out: ≤ 41°C

Notes:

- The manufacturer reserves the right to change these specifications without notice.
- The electrical connector end of the heated air tubing is only compatible with the air outlet at the device end and should not be fitted to the mask.

- Do not use electrically conductive or antistatic air tubing.
- The temperature and relative humidity settings displayed are not measured values.

Displayed values

Value	Range	Display resolution
Pressure sensor at air outlet:		
Mask pressure	2–30 cm H ₂ O (2–30 hPa)	0.1 cm H ₂ O (0.1 hPa)
Flow derived values:		
Leak	0–120 L/min	1 L/min
Tidal volume	0–4000 mL	1 mL
Respiratory rate	0–50 BPM	1 BPM
Minute ventilation	0–30 L/min	0.1 L/min
Ti	0.1–4.0 sec	0.1 sec
I:E ratio	1:100–2:1	0.1

Value	Accuracy ¹
Pressure measurement ¹ :	
Mask pressure ²	±[0.5 cm H ₂ O (0.5 hPa) + 4% of measured value]
Flow and flow derived values ¹ :	
Flow	±6 L/min or 10% of reading, whichever is greater, at 0 to 150 L/min positive flow
Leak ²	±12 L/min or 20% of reading, whichever is greater, 0 to 60 L/min
Tidal volume ^{2,3}	±20%
Respiratory rate ^{2,3}	±1.0 BPM
Minute ventilation ^{2,3}	±20%

¹ Results are expressed as STPD (Standard Temperature and Pressure, Dry). 101.3kPa at an operating temperature of 68°F (20°C), dry.

² Accuracy may be reduced by the presence of leaks, supplemental oxygen, tidal volumes <100 mL or minute ventilation <3 L/min.

³ Measurement accuracy verified as per EN ISO 10651-6:2009 for Home Care Ventilatory Support Devices (Figure 101 and Table 101) using nominal ResMed mask vent flows.

Measurement system uncertainties

In accordance with ISO 80601-2-70:2015 the measurement uncertainty of the manufacturer's test equipment is:

For measures of flow	± 1.5 L/min or ± 2.7% of reading (whichever is greater)
For measures of volume (< 100 mL)	± 5 mL or 6% of reading (whichever is greater)
For measures of volume (≥ 100 mL)	± 20 mL or 3% of reading (whichever is greater)
For measures of pressure	± 0.15 cm H ₂ O (0.15 hPa)
For measures of time	± 10 ms

Pressure accuracy - CPAP

Maximum static pressure variation at 10 cm H₂O (10 hPa) according to ISO 80601-2-70:2015

	Standard air tubing	SlimLine air tubing
Without humidification	± 0.5 cm H ₂ O (± 0.5 hPa)	± 0.5 cm H ₂ O (± 0.5 hPa)
With humidification	± 0.5 cm H ₂ O (± 0.5 hPa)	± 0.5 cm H ₂ O (± 0.5 hPa)

Maximum dynamic pressure variation according to ISO 80601-2-70:2015

Pressure [cm H ₂ O (hPa)]	Device without humidification and Standard air tubing / Device with humidification and Standard air tubing		
	10 BPM	15 BPM	20 BPM
4	0.5 / 0.5	0.5 / 0.5	0.8 / 0.8
8	0.5 / 0.5	0.5 / 0.5	0.8 / 0.8
12	0.5 / 0.5	0.5 / 0.5	0.8 / 0.8
16	0.5 / 0.5	0.5 / 0.5	0.8 / 0.8
20	0.5 / 0.5	0.5 / 0.5	0.8 / 0.8

Device without humidification and SlimLine air tubing / Device with humidification and SlimLine air tubing			
Pressure [cm H ₂ O (hPa)]	10 BPM	15 BPM	20 BPM
4	0.5 / 0.5	0.5 / 0.5	0.8 / 0.8
8	0.5 / 0.5	0.5 / 0.5	0.8 / 0.8
12	0.5 / 0.5	0.5 / 0.5	0.8 / 0.8
16	0.5 / 0.5	0.5 / 0.5	0.8 / 0.8
20	0.5 / 0.5	0.5 / 0.5	0.8 / 0.8

Pressure accuracy - bilevel

Maximum dynamic pressure variation according to ISO 80601-2-70:2015.

Device without humidification and Standard air tubing / Device with humidification and Standard air tubing

Breath rate	Inspiratory pressure (cm H ₂ O [hPa]) (Means, Standard Deviations)					
	6	10	16	21	25	30
10 BPM	-0.09, 0.01 /	-0.01, 0.07 /	0.07, 0.05 /	-0.03, 0.09 /	0.12, 0.01 /	0.12, 0.01 /
	-0.22, 0.01	-0.22, 0.01	-0.24, 0.01	-0.29, 0.03	-0.26, 0.02	-0.14, 0.02
15 BPM	0.02, 0.08 /	0.12, 0.01 /	0.15, 0.01 /	0.15, 0.01 /	0.16, 0.12 /	0.20, 0.05 /
	-0.22, 0.01	-0.22, 0.01	-0.26, 0.01	-0.31, 0.02	-0.30, 0.02	-0.22, 0.02
20 BPM	0.17, 0.01 /	0.21, 0.01 /	0.25, 0.01 /	0.21, 0.17 /	0.32, 0.02 /	0.34, 0.02 /
	-0.23, 0.01	-0.28, 0.01	-0.34, 0.01	-0.38, 0.02	-0.40, 0.03	-0.34, 0.03
Breath rate	Expiratory pressure (cm H ₂ O [hPa]) (Means, Standard Deviations)					
	2	6	12	17	21	25
10 BPM	-0.14, 0.01 /	-0.16, 0.01 /	-0.11, 0.10 /	-0.16, 0.05 /	-0.17, 0.05 /	0.04, 0.17 /
	-0.27, 0.01	-0.29, 0.02	-0.34, 0.02	-0.33, 0.01	-0.33, 0.02	-0.21, 0.01
15 BPM	-0.16, 0.01 /	-0.20, 0.01 /	-0.20, 0.05 /	-0.21, 0.05 /	-0.23, 0.08 /	0.04, 0.21 /
	-0.25, 0.01	-0.33, 0.02	-0.35, 0.01	-0.38, 0.02	-0.38, 0.02	-0.25, 0.01
20 BPM	-0.27, 0.01 /	-0.26, 0.02 /	-0.25, 0.01 /	-0.29, 0.01 /	-0.31, 0.01 /	-0.13, 0.23 /
	-0.37, 0.01	-0.34, 0.01	-0.38, 0.01	-0.43, 0.02	-0.45, 0.03	-0.31, 0.01

Device without humidification and SlimLine air tubing / Device with humidification and SlimLine air tubing

Breath rate	Inspiratory pressure (cm H ₂ O [hPa]) (Means, Standard Deviations)					
	6	10	16	21	25	30
10 BPM	-0.26, 0.01 /	-0.25, 0.02 /	-0.24, 0.02 /	-0.25, 0.02 /	-0.20, 0.02 /	-0.07, 0.09 /
	-0.52, 0.01	-0.53, 0.02	-0.53, 0.01	-0.54, 0.02	-0.51, 0.02	-0.18, 0.02
15 BPM	-0.26, 0.01 /	-0.25, 0.01 /	-0.26, 0.01 /	-0.31, 0.03 /	-0.30, 0.05 /	0.18, 0.08 /
	-0.51, 0.01	-0.54, 0.01	-0.56, 0.01	-0.58, 0.02	-0.60, 0.03	-0.25, 0.02
20 BPM	-0.25, 0.02 /	-0.25, 0.02 /	-0.34, 0.02 /	-0.36, 0.02 /	-0.36, 0.03 /	0.36, 0.02 /
	-0.52, 0.01	-0.58, 0.01	-0.62, 0.01	-0.67, 0.02	-0.69, 0.02	-0.40, 0.02
Breath rate	Expiratory pressure (cm H ₂ O [hPa]) (Means, Standard Deviations)					
	2	6	12	17	21	25
10 BPM	-0.28, 0.01 /	-0.30, 0.03 /	-0.30, 0.01 /	-0.33, 0.01 /	-0.34, 0.01 /	-0.27, 0.01 /
	-0.43, 0.01	-0.50, 0.01	-0.54, 0.01	-0.58, 0.01	-0.60, 0.02	-0.30, 0.01
15 BPM	-0.24, 0.02 /	-0.29, 0.02 /	-0.35, 0.01 /	-0.38, 0.01 /	-0.42, 0.02 /	-0.33, 0.01 /
	-0.37, 0.01	-0.47, 0.01	-0.55, 0.01	-0.62, 0.02	-0.66, 0.01	-0.36, 0.01
20 BPM	0.05, 0.21 /	-0.31, 0.02 /	-0.37, 0.02 /	-0.43, 0.02 /	-0.48, 0.02 /	-0.43, 0.02 /
	-0.38, 0.01	-0.50, 0.02	-0.57, 0.02	-0.65, 0.02	-0.68, 0.02	-0.45, 0.01

Note: The table above is based on data that covers between 60.1 and 88.8% of the inspiratory phase and 66.1 and 93.4% of the expiratory phase durations. These data time slots start immediately after the initial transient overshoot/undershoot periods and end at the point that flow diminishes to an equivalent absolute value of its starting point, towards the end of the breath phases (this corresponds to the % ranges of values given immediately above).

























Flow (maximum) at set pressures

The following are measured accordingly to ISO 80601-2-70:2015 at the end of the specified air tubing:

Pressure cm H ₂ O (hPa)	Lumis and Standard L/min	Lumis, humidification and Standard L/min	Lumis and SlimLine L/min	Lumis, humidification and ClimateLineAir L/min
4	180	143	162	151
8	168	135	151	142
12	157	136	140	135
16	144	134	128	121
20	131	123	117	109
25	120	115	96	84

Symbols

The following symbols may appear on the product or packaging.

 Read instructions before use.  Indicates a warning or caution.  Follow instructions before use.  Manufacturer.  European Authorised Representative.  Batch code.  Catalogue number.  Serial number.  Device number.  On / Off.  Device weight.  Protected against finger sized objects and against dripping water when tilted up to 15 degrees from specified orientation.  Direct current.  Type BF applied part.  Class II equipment.  Humidity limitation.  Temperature limitation.  Non-ionising radiation.  China pollution control logo 1.  China pollution control logo 2. **Rx Only** Prescription only (In the US, Federal law restricts these devices to sale by or on the order of a physician).  Maximum water level.  Use distilled water only.  Operating altitude.  Atmospheric pressure limitation.  Complies with RTCA DO-160 section 21, category M.



Environmental information

This device should be disposed of separately, not as unsorted municipal waste. To dispose of your device, you should use appropriate collection, reuse and recycling systems available in your region. The use of these collection, reuse and recycling systems is designed to reduce pressure on natural resources and prevent hazardous substances from damaging the environment.

If you need information on these disposal systems, please contact your local waste administration. The crossed-bin symbol invites you to use these disposal systems. If you require information on collection and disposal of your ResMed device please contact your ResMed office, local distributor or go to www.resmed.com/environment.

Servicing

The Lumis device is intended to provide safe and reliable operation when operated in accordance with the instructions provided by ResMed. ResMed recommends that the Lumis device be inspected and serviced by an authorised ResMed Service Centre if there is any sign of wear or concern with device function. Otherwise, service and inspection of the products generally should not be required during their design life.

Limited warranty

ResMed Ltd (hereafter 'ResMed') warrants that your ResMed product shall be free from defects in material and workmanship from the date of purchase for the period specified below.

Product	Warranty period
<ul style="list-style-type: none"> Mask systems (including mask frame, cushion, headgear and tubing)—excluding single-use devices Accessories—excluding single-use devices Flex-type finger pulse sensors Humidifier water tubs 	90 days
<ul style="list-style-type: none"> Batteries for use in ResMed internal and external battery systems 	6 months
<ul style="list-style-type: none"> Clip-type finger pulse sensors CPAP and bilevel device data modules Oximeters and CPAP and bilevel device oximeter adapters Humidifiers and humidifier cleanable water tubs Titration control devices 	1 year
<ul style="list-style-type: none"> CPAP, bilevel and ventilation devices (including external power supply units) Battery accessories Portable diagnostic/screening devices 	2 years

This warranty is only available to the initial consumer. It is not transferable.

If the product fails under conditions of normal use, ResMed will repair or replace, at its option, the defective product or any of its components.

This Limited Warranty does not cover: a) any damage caused as a result of improper use, abuse, modification or alteration of the product; b) repairs carried out by any service organisation that has not been expressly authorised by ResMed to perform such repairs; c) any damage or contamination due to cigarette, pipe, cigar or other smoke; and d) any damage caused by water being spilled on or into an electronic device.

Warranty is void on product sold, or resold, outside the region of original purchase.

Warranty claims on defective product must be made by the initial consumer at the point of purchase.

This warranty replaces all other expressed or implied warranties, including any implied warranty of merchantability or fitness for a particular purpose. Some regions or states do not allow limitations on how long an implied warranty lasts, so the above limitation may not apply to you.

ResMed shall not be responsible for any incidental or consequential damages claimed to have resulted from the sale, installation or use of any ResMed product. Some regions or states do not allow the exclusion or limitation of incidental or consequential damages, so the above limitation may not apply to you.

This warranty gives you specific legal rights, and you may also have other rights which vary from region to region. For further information on your warranty rights, contact your local ResMed dealer or ResMed office.

**ResMed Ltd**

1 Elizabeth Macarthur Drive
Bella Vista NSW 2153 Australia

Distributed by

ResMed Corp 9001 Spectrum Center Boulevard San Diego CA 92123 USA
EC REP ResMed (UK) Ltd 96 Jubilee Ave Milton Park Abingdon Oxfordshire OX14 4RW UK

See ResMed.com for other ResMed locations worldwide. Air10, Lumis, ClimateLine, SlimLine, HumidAir, SmartStart, ResScan, AirView and VPAP are trademarks and/or registered trademarks of the ResMed family of companies. For patent and other intellectual property information, see ResMed.com/ip. Actichlor is a trademark of Ecolab US Inc. Alconox is a trademark of Alconox Inc. Cavicide is a registered trademark of Metrex Research, LLC. CIDEX is a registered trademark of Advanced Sterilization Products, Division of Ethicon US, LLC. MikroZid and Terralin are trademarks of Schülke & Mayr GmbH. Neodisher MediZym is a trademark of Chemische Fabrik Dr Weigert GmbH & Co. KG. Gigasept is a trademark of Schülke & Mayr. Sterrad is a trademark of Johnson & Johnson. SD Logo is a trademark of SD-3C, LLC.

© 2015 ResMed Ltd. 288244/1 2015-09

CE 0123
0682