

Year Manufactured	1987
Registration	
Total Airframe Hours	41835 (at 8 th SEP 2020)
Total Airframe Cycles	44348 (at 8 th SEP 2020)

LEADING PARTICULARS

Maximum take-off weight	28500 lb	12930 kg
Maximum landing weight	27200 lb	12340 kg
Maximum zero fuel weight	25700 lb	11660 kg
Basic empty weight	18330 lb	8332 kg
Maximum fuel weight	5690 lb	2580 kg

CABIN

34 blue leather PAX seats, 10 single seats/12 double seats; fwd lavatory with external service; L/H galley; 2 trollies; 2 hot jugs; blue carpets and kick panel

MAINTENANCE CHECK STATUS

System & Powerplant	Next Due at	Remarks
4000 FH – C1 Check	44458 FH	2623 FH remains
8000 FH – C2 Check	44524 FH	2688 FH remains
Corrosion		
4/2 Y	10.MAR.2022	Interval 2 Y
6/4 Y	09.MAR.2024	Interval 4 Y
Structural		
30K/3K Cyc	45238 Cyc	890 Cyc remains
30K/6K Cyc	46333 Cyc	1985 Cyc remains
30K/12K Cyc	54238 Cyc	9890 Cyc remains

SAAB 340A

Even though care has been taken in compiling information in this document, no warranty is made or implied as to the accuracy or completeness of the data presented, which is all subject to the buyer's/lessee's verification upon inspection of the aircraft and records.

**POWERPLANT - GENERAL ELECTRIC - MODEL CT7-5A2
(ON CONDITION)**

Position	Left	Right
Serial number		
Time since new	33242 FH	29449 FH
Cycles since new	28808 Cyc	28807 Cyc
Time since last shop visit	7287 FH	5604 FH
Cycles since last shop visit	5464 Cyc	2738 Cyc
Last shop visit	24.JUL.2012 H+S	17.AUG.2015 H+S

**PROPELLERS - DOWTY ROTOL (TBO 7500 FH OR 5 YEARS) MODEL
R389/4-123-F/25, R389/4-123-F/26**

Position	Left	Right
Serial number		
Time since new	34216 FH	33832 FH
Time since overhaul	1966 FH	5380 FH
Due calendar time	03.MAY.2023	15.DEC.2024
Last OVH date	04.MAY.2018	02.APR.2014
Last calendar extension	None since OVH	17.DEC.2019

LANDING GEAR - APPH (CBO 12000 CYC, TBO 10 Years)

Item	Part Number	Cyc Since OVH	Last OVH date	Installation date
Nose shock strut		2110 Cyc	28.SEP.2016	24.JAN.2017
Nose drag brace		6141 Cyc	18.APR.2011	16.NOV.2019
Left MLG shock strut		2110 Cyc	26.SEP.2016	24.JAN.2017
Left MLG drag brace		6243 Cyc	08.APR.2011	22.AUG.2019
Right MLG shock strut		4014 Cyc	03.APR.2013	23.AUG.2013
Right MLG drag brace		6243 Cyc	13.DEC.2011	22.AUG.2019

SAAB 340A

Even though care has been taken in compiling information in this document, no warranty is made or implied as to the accuracy or completeness of the data presented, which is all subject to the buyer's/lessee's verification upon inspection of the aircraft and records.

AVIONICS

Qty	Item	Vendor	Model
2	VHF transceiver	Collins	VHF22C
1	Cockpit voice recorder	HONEYWELL	SSCVR
1	FDR	L-3	Solid state F1000
1	Autopilot	Collins	APP-85
2	RMI	Aeronetics	D3337L-B-2-1-S/SB-
1	Weather radar	Collins	WXT-250B
1	Radio altimeter	Collins	ALT-55B
1	EGPWS	Honeywell	MK VI
2	ADF	BendixKing	KDF-806
2	ATC transponder	Collins	TDR 94D
4	EFD	Collins	EFD-86
2	VOR/ILS/MKR	BendixKing	KNR 634A
2	DME	BendixKing	KDM-706A
1	ELT	Air Precision	ELT96
2	Attitude/Heading	Collins	AHC-85
1	Air Data Computer	Collins	ADC-81A
1	TCAS	Collins	TTR921
1	FMS	Universal	UNS-1K

Aircraft dimensions		
Length	64 ft 11 in	19.79 m
Height	22 ft 11 in	6.97 m
Wing span	70 ft 4 in	21.44 m
Passenger door(HxW)	63.7 in x 26.8 in	1.62 m x 0.68 m
Cargo door (HxW)	51.0 in x 53.0 in	1.30 m x 1.35 m
Capacity		
Cabin length	34 ft	10.36 m
Cabin width	7 ft 1 in	2.20 m
Headroom	6 ft 0 in	1.80 m
Aisle width	16.3 in	0.40 m
Max cabin pressure differential	7.0 psi	49.2 kPa

SAAB 340A

Even though care has been taken in compiling information in this document, no warranty is made or implied as to the accuracy or completeness of the data presented, which is all subject to the buyer's/lessee's verification upon inspection of the aircraft and records.

Baggage volume		
Overhead bin (gen I)	32.4 ft ³	0.92 m ³
Underset	40.8 ft ³	1.16 m ³
Rear cargo	240 ft ³	6.80 m ³
Total baggage volume	313.2 ft ³	8.88 m ³
Total baggage volume/pax	9.8 ft ³	0.28 m ³

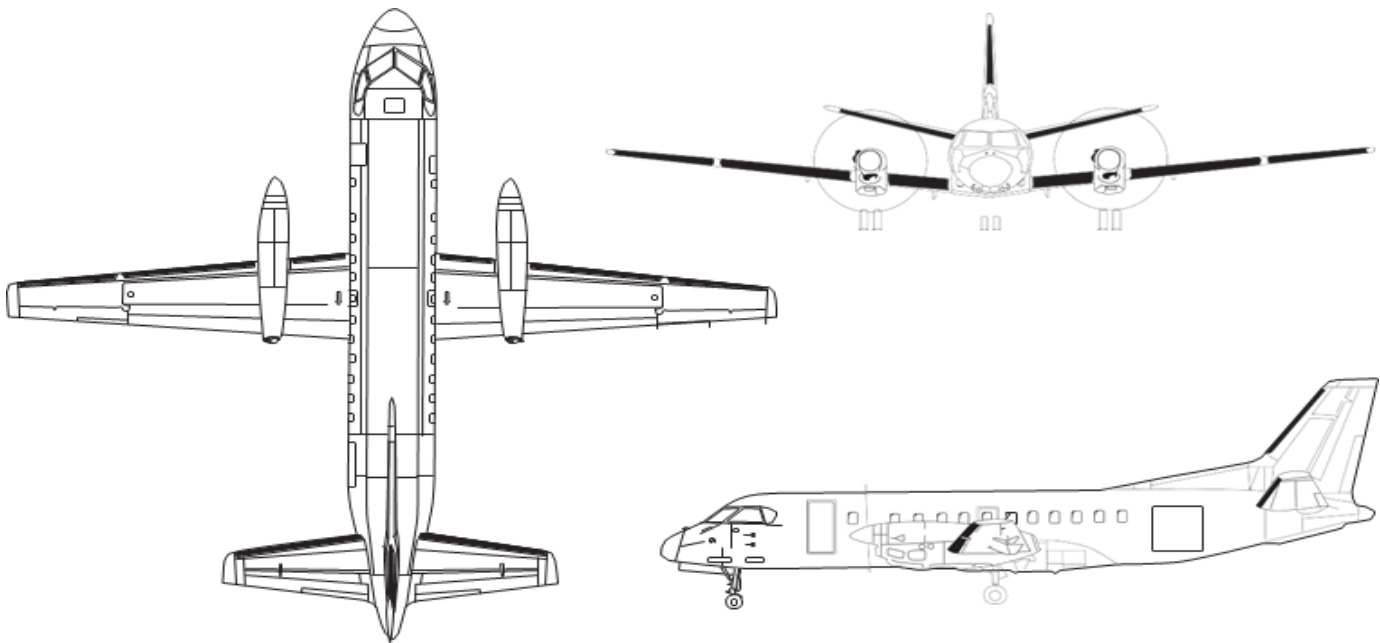

SAAB 340A

Even though care has been taken in compiling information in this document, no warranty is made or implied as to the accuracy or completeness of the data presented, which is all subject to the buyer's/lessee's verification upon inspection of the aircraft and records.

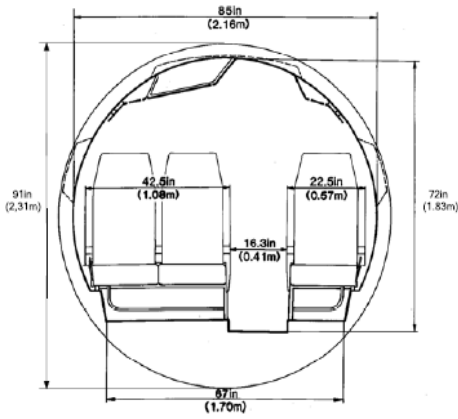
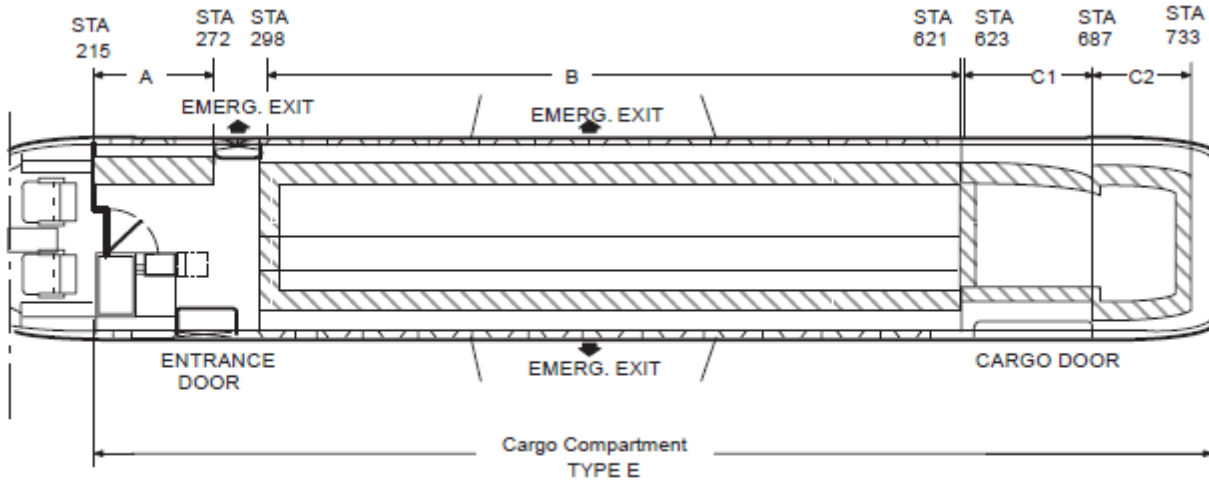

SAAB 340A

Even though care has been taken in compiling information in this document, no warranty is made or implied as to the accuracy or completeness of the data presented, which is all subject to the buyer's/lessee's verification upon inspection of the aircraft and records.