



ENERGY STORAGE SYSTEM

USER MANUAL

LEADING A GREEN NEW LIFE

Please read this manual carefully before installing the system and carry out the installation procedures as per the instructions

TABLE OF CONTENTS

PREFACE	01
CHAPTER 1: INTRODUCTION	02
SECTION 1.1 : SYMBOLS USED.....	04
CHAPTER 2 : PRECAUTIONS.....	07
CHAPTER 3: INSTALLATION CYCLE.....	08
SECTION3.1: CHECK KIT COMPONENTS.....	09
SECTION3.2: READ THE INSTRUCTION MANUAL.....	09
SECTION3.3: CHECK INSTALLATION TOOLS.....	10
SECTION3.4: RISK ASSESSMENT/COMPLIANCE TO STANDARDS.....	11
SECTION3.5: REQUIREMENTS FOR WALL OR SUPPORT	11
SECTION3.6: IDENTIFY A SUITABLE LOCATION FOR THE BIUESUN.....	13
SECTION3.7: INSTALLATION SPACE PLANNING.....	14
SUBSECTION3.7.1:BSM5KLNA-HY IN SERIES	14
CHAPTER4: INSTALLATION.....	15
SECTION4.1: INSTALLATION OF MOUNTING PLATE.....	15
SECTION4.2: INSTALLATION OF BSM5KLNA-HY.....	16
CHAPTER5: WIRING.....	17
CHAPTER6: COMMISSIONING, OPERATING AND MAINTENANCE.....	19
SECTION6.1: COMMISSIONING.....	19
SECTION6.2: OPERATING.....	20
SECTION6.3:BSM5KLNA-HY CARE.....	21
SECTION6.4: MAINTENANCE.....	21
CHAPTER7: APPENDICES.....	22
SECTION7.1: TROUBLESHOOTING.....	22
SECTION7.2: EMERGENCY SITUATION.....	22
SECTION7.3: SPECIFICATIONS.....	23
SECTION7.4: WARRANTY CLAIMS AND PERFORMANCE.....	24

Preface

What is an BSM5KLNA-HY system ?

BSM5KLNA-HY is a modular lithium-Ion energy storage system which can help to optimize the use of residential solar energy systems, cut the electricity bills and reduce carbon footprint. The BSM5KLNA-HY is with an aesthetically pleasing appearance and electrical safety design, a lifespan of more than 10 years can be expected. Its Intelligent Identification and automatic equalization design allow multiple units to be connected together for system storage capacity expansion easily.

How does it work ?

Your solar PV system can produce energy during daylight hours that can be used to help power your home and other equipment. Surplus electricity generated from the solar panels during the day is stored in the BSM5KLNA-HY for later use at night or during a power outage. The BSM5KLNA-HY stored energy is provided to your home by a Power Conversion System (PCS) unit which is sold separately. Off-peak electricity from the grid can be stored in the BSM5KLNA-HY for re-sale to the grid via the PCS.

How It Works

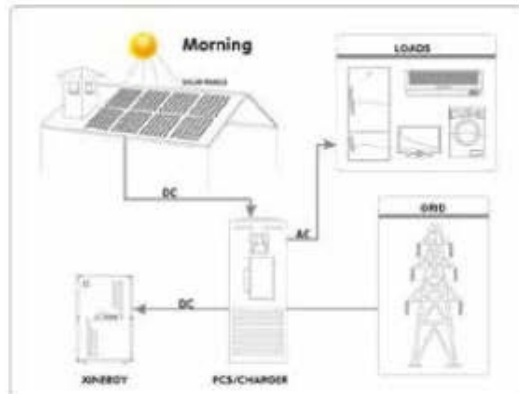

Optimized self-consumption will be achieved. Batteries are used to store the excess energy produced by the PV Systems.

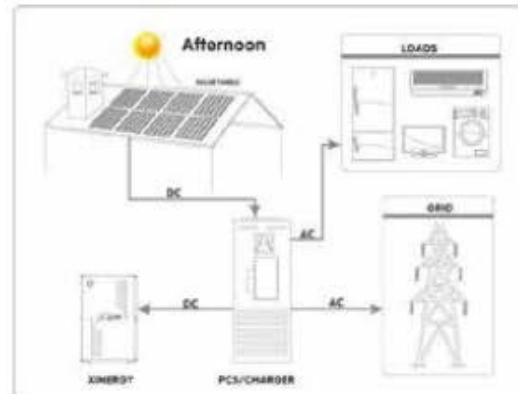

Extra energy will be fed into the grid when batteries are fully charged and the system has already met its self-consumption requirement.

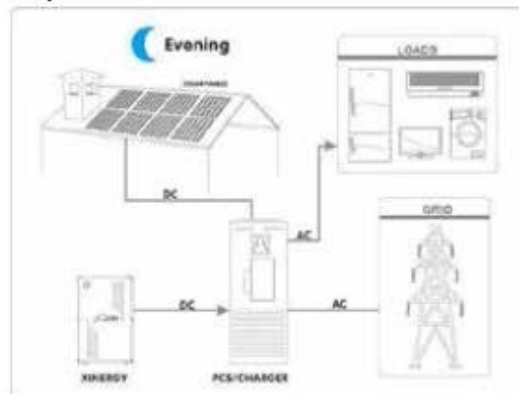

Batteries will power the AC load when the sun sets.

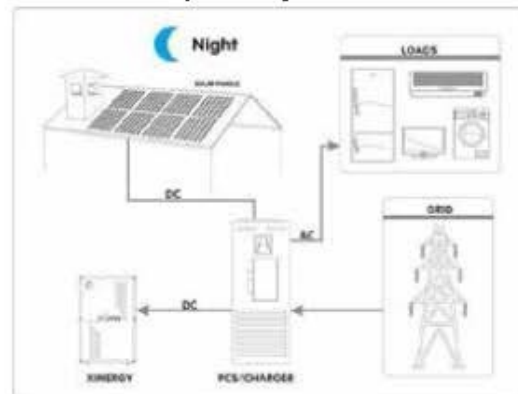

If the battery capacity is insufficient to meet self-consumption requirement, electricity will be obtained from the grid.

CHAPTER 1: INTRODUCTION

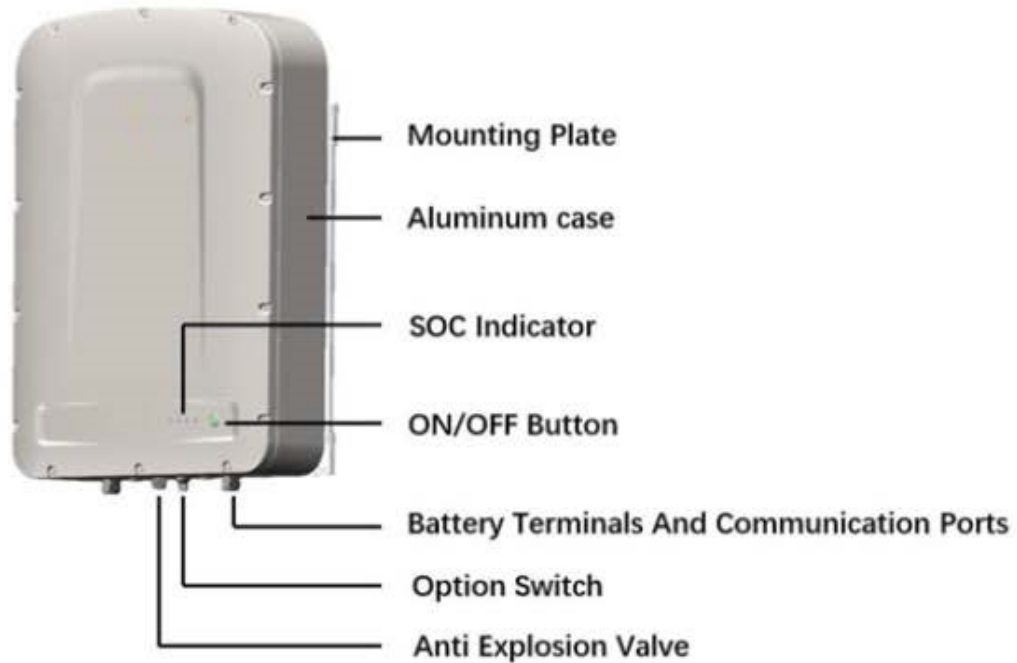

Items	Description
On/off button	Used as battery indicator and mode switching
Battery terminals and communication ports	Used to connect with PCS and operate the system
Safety switch	Used as the main circuit switch; Protect the circuit and avoid unexpected issues occurring
Aluminum case	Used for natural cooling
Mounting plate	Used for fixing the BSM5KLNA-HY on the wall
SOC Indicator	The four indicator lights equate to 25% charge each from left to right
Anti Explosion Valve	Explosion-proof valve for pressure release inside battery

The purpose of this document is to provide information for the owner and guidelines for the installer to help ensure that the BSM5KLNA-HY energy storage system is properly installed and operates to its designed potential. This document sets out key criteria that describe a quality system and key design and installation considerations that should be met in order to achieve this goal. This document deals with BSM5KLNA-HY energy storage system and is applicable for the following BLUESUN energy storage system models:

BSM-U-48V/5.76kWh

These systems should be installed by competent installers who have completed an Energy storage system installer training course. BLUESUN has worked closely with distributors in each country to develop an energy storage system training course. All specifications and descriptions contained in this document are verified to be accurate at the time of printing. Continuous improvement is a goal at BLUESUN and we reserve the right to make product modifications at any time.







The images provided in this document are for demonstration purposes only. Depending on the product version and market region details may appear slightly different. Please visit our website <http://www.bluesunpv.com> to learn more about the BSM5KLNA-HY energy storage system training and how to obtain installer certification.









Thank you for choosing the BLUESUN BSM5KLNA-HY system, we are certain that with proper operation and maintenance our system will provide you with clean renewable solar electricity for many years.







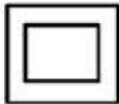

This manual does not list all precautions needed for safe work. Any energy storage system must comply with the Health and Safety Requirements and other relevant standards and Codes of Practice within the country of installation. This manual provides guidelines for installation but it does not guarantee the quality of installation work. Please complete all work in a responsible and professional manner.

All electrical work should be performed by a qualified electrician. It is the qualified installer's responsibility to ensure that the BSM5KLNA-HY is suitable for your use and that the PCS is also certified for use by BLUESUN to deliver the best outcomes.

SECTION 1.1: SYMBOLS USED

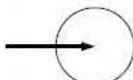
Symbols	Description
	CAUTION! CAUTION represents hazardous situations which can cause light injuries if not avoided.
	NOTICE! NOTICE represents the situations which can cause damage to property if not avoided.
	INFORMATION "INFORMATION" provides tips that are valuable for optimum installation and operation of the product.
	Beware hot surface. The inverter can get hot during operation. Avoid contact in operation.
	Follow the guidelines of all relevant documents.
	Do not dispose of the inverter with household wastes. For detailed disposal information, please refer to the installation manual provided.

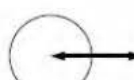
Number	Symbol	Description
1		Direct current
2		Alternating current
3		Both direct and alternation current
4	3~	Three-phase alternating current
5	3N~	Three-phase alternating current with neutral conductor
6		Earth terminal
7		Protective conductor terminal
8		Frame or chassis terminal
9		Refer to the operating instructions
10		ON(supply)
11		OFF(supply)
12		Equipment protected throughout by double insulation or reinforced insulation

Number	Symbol	Description
13		Caution, risk of electric shock
14		Caution hot surface
15		Caution, risk of danger
16		In position of a push button control
17		Out position of a push button control
18		Input terminal or rating
19		Output terminal or rating
20		Bidirectional terminal rating
21		Caution, risk of electric shock, Energy storage timed discharge
22		Caution, risk of hearing damage. Wear hearing protection

CHAPTER 2: PRECAUTIONS

WARNING

Failure to observe the precaution described in this section can cause serious injury to persons or damage to property.

Observe the following precautions:

Risks of explosion

- ◆ Do not subject the BSM5KLNA-HY to strong impacts.
- ◆ Do not crush or puncture the BSM5KLNA-HY.
- ◆ Do not dispose of the BSM5KLNA-HY in a fire.

Risks of fire

- ◆ Do not expose the BSM5KLNA-HY to temperatures in excess of 50°C.
- ◆ Do not place the BSM5KLNA-HY near a heat source such as a fireplace.
- ◆ Do not expose the BSM5KLNA-HY to direct sunlight.
- ◆ Do not allow the battery connectors to touch conductive objects such as wires.

Risks of electric shock

- ◆ Do not disassemble the BSM5KLNA-HY.
- ◆ Do not touch the BSM5KLNA-HY with wet hands.
- ◆ Do not expose the BSM5KLNA-HY to moisture or liquids.
- ◆ Keep the BSM5KLNA-HY away from children and animals.

Risks of damage to the BSM5KLNA-HY

- ◆ Do not allow the BSM5KLNA-HY to come in contact with liquids.
- ◆ Do not subject the BSM5KLNA-HY to high pressures.
- ◆ Do not place any objects on top of the BSM5KLNA-HY.

It is recommended to wear the following safety gear when connecting the BSM5KLNA-HY with PCS.



Insulated Gloves



Safety Glasses



Safety Shoes

CHAPTER 3: INSTALLATION CYCLE









The scope of this document includes the installation of the BSM5KLNA-HY to a wall or support structure, the connection of the D.C. wiring to the PCS, and provides information regarding the A.C. wiring required to connect the PCS into the building's electricity supply. A typical project cycle for a BLUESUN energy storage system is shown below. It shows consideration of the BSM5KLNA-HY system from the start of the project through the stages of installation, commissioning, and finishing with operation and maintenance considerations.

Installation Cycle

01	Check kit contents
02	Read instruction manual
03	Check installation tools
04	Risk assessment/Planning permission
05	Requirements for Wall or Support
06	Identify a suitable location for the BSM5KLNA-HY
07	Installation space planning
08	Installation & Wiring

SECTION 3.1: CHECK KIT COMPONENTS

Check kit contents against the included part list with component descriptions and quantities. Ensure all components and quantities are present before starting the installation project

KITS	PICTURES
BSMSKLNA-HY	 ×1
Mounting Plate	 ×1
Expansion screw (M8*20)	 ×8(self-provided)
Connector wire (25mm ²)	 ×2(self-provided)
Ethernet cable (Super Five Networks)	 ×1(self-provided)
Modular connector (BPBC)	 ×2(self-provided)
Modular adapter (3 WAYS)	 (Multi-machine parallel connection is applicable)
Modular adapter (1WAY)	 (Multi-machine parallel connection is applicable)

SECTION 3.2: READ THE INSTRUCTION MANUAL

All of the instructions should be thoroughly read and understood before attempting to install, wire, operate and maintain the BSM5KLNA-HY energy storage system. Contact with electrically active parts of the system such as terminals can result in burns, sparks, and lethal shock whether the module is connected or disconnected. The installation of the BSM5KLNA-HY should only be performed by a qualified licensed professional, including, without limitation, licensed contractors and licensed electricians. Please keep this manual for reference.

SECTION 3.3: CHECK INSTALLATION TOOLS

TOOLS	PICTURE	DESCRIPTION
Percussion drilling (M14)		Drill the wall
Screwdriver		Connect the wire to the battery
Torque wrench (M8)		Fix the expansion screws
Insulated rubber tape		To prevent leakage and insulate wires
Multi-meter		Testing the connections
Claw hammer		Hit the screws
Crimping Pliers		Assemble the Ethernet cable with Modular connector to RJ45(T568B)
Utility knife		Modify the wires
Levelling instrument		To conduct the leveling measurement

SECTION 3.4: RISK ASSESMENT/COMPLIANCE TO STANDARDS

The BSM5KLNA-HY energy storage system can power your home by combing with a PCS to store PV generated electricity to create a solution for residential and light commercial properties.

Installation standards vary between countries and as such we recommend in all cases that you check with your local standards authority before you commit to installing our energy storage system. This document does not address health, safety, electrical or building regulations matters, a site assessment and works method statement should be completed prior to commencing the installation.

SECTION 3.5: REQUIREMENTS FOR WALL OR SUPPORT

WARNING

- ◆ The BSM5KLNA-HY should be installed to a wall capable of supporting its weight, interior walls are preferred but where installation is on an exterior wall it should be protected from direct rain contact and sunlight.
- ◆ Local building regulations and standards should be observed to consider any fire ratings that may be applicable.





SECTION 3.6: IDENTIFY A SUITABLE LOCATION

- ◆ Make sure the weight capacity of bracket location is greater than 80kg
- ◆ Make sure the location is not easily accessible by children and in an area free from explosive or corrosive atmospheres.
- ◆ For residential installations the energy storage is typically located in a secure well ventilated location shielded from direct sunlight and rain.
- ◆ The BSM5KLNA-HY must be mounted vertically on a wall or pole. Do not mount horizontally as adequate heat dissipation cannot be ensured.
- ◆ Make sure the BSM5KLNA-HY is mounted in a location where the ambient temperature range is -10 to +45 °C . The BSM5KLNA-HY may shut down automatically if it excessive heat or cold temperatures.
- ◆ A space of at least 100mm to 300mm around the enclosure guarantees optimum ventilation.
- ◆ The 1000mm lower clearance is only recommended where children could access the BSM5KLNA-HY and touch the heat sink/chassis.
- ◆ Unless walls are properly insulated, avoid mounting the BSM5KLNA-HY on any wall that is directly exposed to the sun or a heat source such as a boiler room wall.
- ◆ Only work on the BSM5KLNA-HY when it is fully disconnected and observe the heat sink temperature. Work should only be carried out by qualified person.
- ◆ To minimize resistance and power loss, the customer should make sure to minimize the wire lengths among the BSM5KLNA-HY, the PCS and the main utility service panel.
- ◆ Ensure the BSM5KLNA-HY is mounted beside this cable entry to ensure successful connection to the PCS.
- ◆ Refer to the installation manual of the PCS manufacturer for further installation procedures and guidelines.

SECTION 3.7:INSTALLATION SPACE PLANNING



CHAPTER 4: INSTALLATION

SECTION 4.1: INSTALLATION FOR MOUNTING PLATE

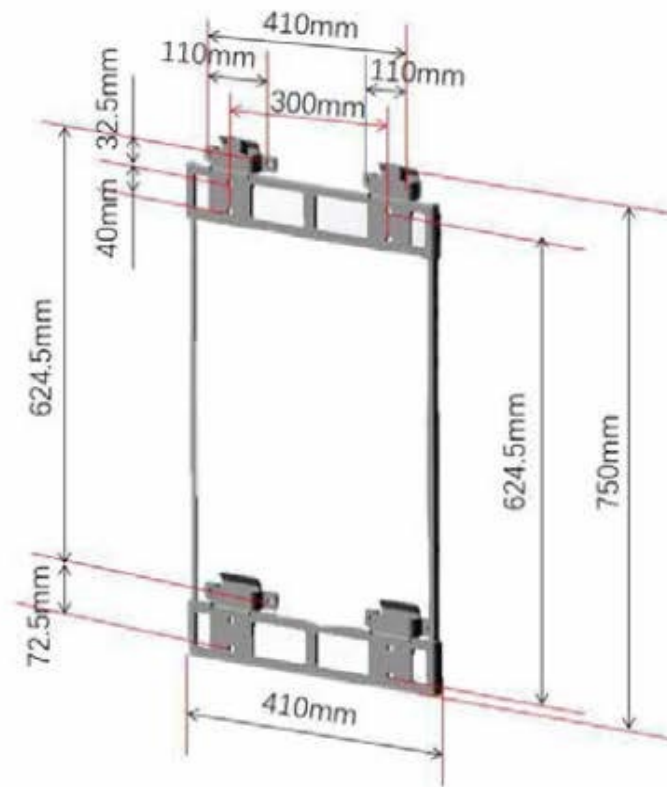

STEP	Description
Step1	Draw lines positioning the holder plate with ruler on the wall
Step2	Drill the screw holes into the wall for 8cm-9cm
Step3	Drill the screw holes

SECTION 4.2: INSTALLATION FOR BSM5KLNA-HY

WARNING

- ◆ BSM5KLNA-HY is heavy and challenging to lift, two person lift is recommended.
- ◆ We recommend that following the schematic instruction to complete the installation.
- ◆ Repeat the same installation process if you have multiple series or parallel installations of the BSM5KLNA-HY, until all the BSM5KLNA-HY have been installed.

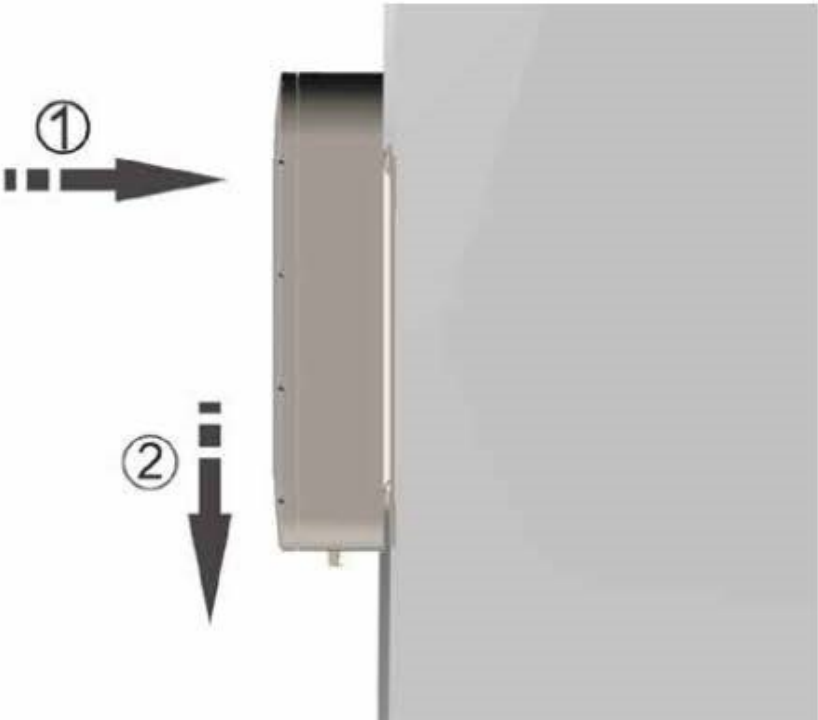

Hang the BSM5KLNA-HY on the mounting plate, observe the schematic instruction

CHAPTER 5: WIRING

WARNING

◆ The BSM5KLNA-HY voltage between, the positive and negative terminals should be measured with a multimeter before and after wiring (Ensure the BSM5KLNA-HY is powered on. Please check P22 for details). The initial voltage should register within **48-54V** DC. if the reading is outside this range then please call your BIUESUN authorized reseller for advice.

◆ It is recommended that the DC cable connection between the PCS and BSM5KLNA-HY is kept to a minimum to minimize line losses. Interconnecting DC cables should also have variation lengths where possible.

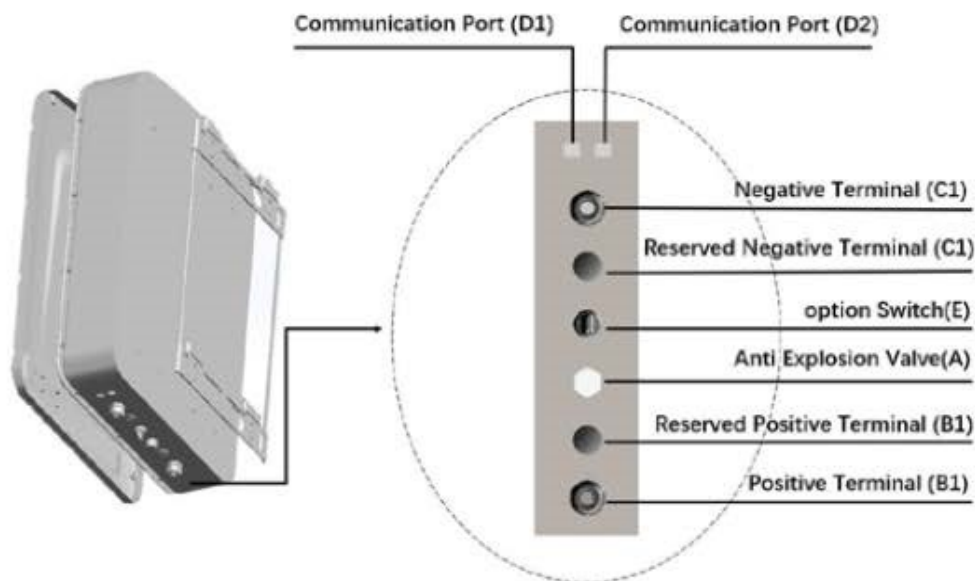

STEP	Description
Step 1	Take off the interface cover.
Step 2	Make sure the safety switch is OFF. PCS is powered off.
Step3	Connect the ethernet cable (RJ45,T568B:4-CANH,5-CANL,7-485B,8-485A) to the communication port D1, and then connect the communication cable coming from the PCS to the communication port through the cable hole.
Step4	If the PCS has a ground wire, connect it to the ground screw through the cable hole.
Step5	Connect the power cables to the terminal block through the cable hole. Connect the positive cable to the positive terminal B1 and the negative cable to the terminal C1.
Step6	Switch on the safety switch.

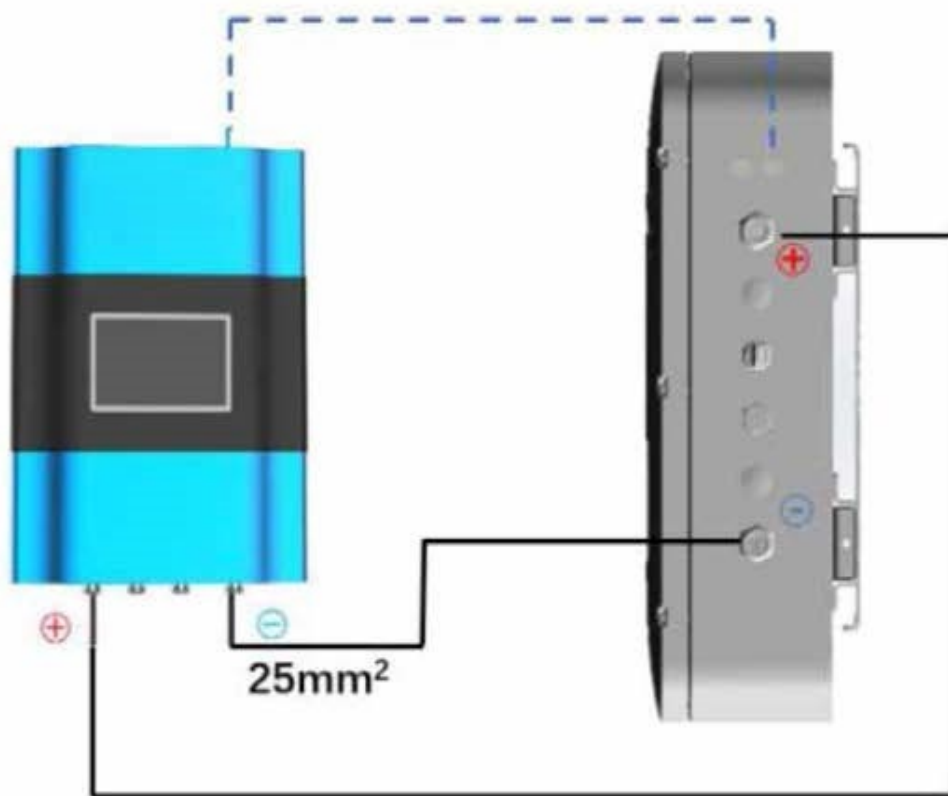

NOTE

- ◆ Design specifications applicable for a maximum of 100 Amp charge/discharge PCS only.
- ◆ Cable sizes are a guide only and sizes should comply with local standards.

CHAPTER 6: COMMISSIONING, OPERATING, AND MAINTENANCE

SECTION 6.1: COMMISSIONING

STEP	Description
Step 1	Hold the on/off button of the BSM5KLNA-HY for over 4 seconds until the button light is in a steady on state Ensure all the BSM5KLNA-HY are powered on.
Step 2	Power on the PCS, select the cell configuration interface (refer to PCS user manual).
Step 3	Select BLUESUN BSM5KLNA-HY in the cell configuration interface. You also can input the specification of BSM5KLNA-HY in the PCS cell configuration interface.
Step 4	Complete other configuration options in the PCS installation manual.
Step 5	Ensure the PCS and BSM5KLNA-HY are connect successfully.
Step 6	An error message will appear on the PCS screen if the connection failed. (refer to the troubleshooting section to solve the problem)
Step 7	If the problem cannot be solved please contact the after sales service of BSM5KLNA-HY and PCS company.

SECTION 6.2: OPERATING

In the Process of using the BSM5KLNA-HY please follow this manual for proper care and use of the product. There are three common modes:

1) Normal mode 2) Standby mode 3) Storage/transport mode

NOTE
<p>◆Make sure to select the same mode for every BSM5KLNA-HY In multiple connection.</p> <p>◆VOCATIONS: For battery protection It is recommended to keep the full system of PV,PCS and BSM5KLNA-HY In operation. Extended periods of shutdown should be avoided.</p>

Mode	STEP	Function	Description
Normal mode (Conditions of use: normal operation)	Step 1	Power on	Hold the on/off button of the BSM5KLNA-HY over 4 seconds until the SOC indicator is a steady state.
	Step 2	Shutdown	Hold the on/off button of the BSM5KLNA-HY over 6 seconds until the SOC indicator extinguishes.
Standby mode (Conditions of use: Suspend the use of BSM5KLNA-HY for less than one week)	Step 3	Auto standby	The BSM5KLNA-HY will enter auto standby mode automatically if no charge or discharge operation is carried out for more than 24 hours.
	Step 4	Wake up	Hold the on/off button of the BSM5KLNA-HY over 4 seconds until the SOC indicator is a steady state.
Storage/Transport mode (Conditions of use:In the process of storage or transport the BSM5KLNA-HY)	Step 5	Forced shutdown	Turn off the safety switch and disconnect all wires.
	Step6	Wake up	Hold the on/off button of the BSM5KLNA-HY over 4 seconds until the SOC indicator is a steady state.

SECTION 6.3: BSM5KLNA-HY CARE

Keep the top edge of BSM5KLNA-HY clear of leaves and other debris to maintain optimal airflow. To clean BSM5KLNA-HY use a soft Lint-free cloth, the cloth can be dampened lightly with water only if required. To avoid possible Injury do not subject the unit to high pressure water cleaning
Caution : Do not use cleaning solvents to clean BSM5KLNA-HY.

SECTION 6.4: MAINTENANCE

BSM5KLNA-HY is not user serviceable and must be repaired by a BIUESUN Certified Installer who has been trained by BIUESUN. If any problems arise refer to troubleshooting on page 24 before contacting the BIUESUN Authorized Reseller who sold the BIUESUN unit.

CHAPTER 7: APPENDICES

SECTION 7.1: TROUBLESHOOTING

If BSM5KLNA-HY is not working correctly perform steps. If the issue persists contact the BLUESUN Authorized Reseller who originally sold the BSM5KLNA-HY unit.

Problem	Solution
BSM5KLNA-HY refuses to operate	check the temperature in the room and increase ventilation if needed
The PCS and BSM5KLNA-HY are both unresponsive	switch off the breaker for the PCS, wait for at least one minute, and then turn it back on
A brownout or blackout is experienced during backup supply	Reduce the loads and check the breakers
It is not possible to communicate with the PCS through its portal	Check the PCS manual to learn about diagnosing BSM5KLNA-HY
	Follow the troubleshooting steps outlined in the PCS manual

SECTION 7.2: EMERGENCY SITUATION

Wet

If the BSM5KLNA-HY is submerged in water do not let people access it and then contact your BLUESUN authorized reseller for technical support.

Damaged

This product uses a special design with multiple layers of security to prevent leakage or fire events. Under strong external shock the BSM5KLNA-HY may emit smoke, in this case please stay away from BSM5KLNA-HY until the smoke disappears, turn off the power supply of the BSM5KLNA-HY, and then return it to BLUESUN authorized reseller.

Damaged BSM5KLNA-HY are dangerous and must be handled with the utmost care, they are not fit for use and may pose a danger to people or property.

If the BSM5KLNA-HY seems to be damaged, pack it in its original container and then return it to your BSM5KLNA-HY authorized reseller.

In the unlikely case where smoke continues to be emitted by the BSM5KLNA-HY make sure that the following equipment is available near it:

SCBA (self-contained breathing apparatus) and protective gear in compliance with the Directive on Personal Protective Equipment 89/686/EEC and either a Novec 1230, FM-200, or dioxide extinguisher.

SECTION 7.3: SPECIFICATIONS

Model	BSM-U-48V/5.76kWh
Capacity	5.76kWh
Depth of discharge	90% DOD
Nominal Voltage	48VDC
Voltage range	39~54VDC
Maximum charging voltage	54DC
Continuous current at 25℃	100A
Continuous current at 35℃	<80A
Continuous current at 45℃	<50A
Maximum pulse current at 25℃, 10s	<115A
Continuous charging current at 25℃	50A
Efficiency	>97%
Operating Condition	Indoor or Outdoor
Operating Temperature	-10℃~45℃
Dimension (L * W * H)	890*643*178mm
Weight	75KG
Cooling Type	Natural cooling
Shell Material	Aluminum
Installation Method	Wall Mounted
IP Rating	IP54
Maximum of Parallel	8
Parallel Setting	Auto Sensing
Warranty	6200 Cycles
Life Span	>10 Years
Communication Mode	RS485,CAN
Protection Mode	Triple Hardware Protection
Battery Protection	Over-current,Over-voltage,Short circuit,Under-voltage,Over-temperature

SECTION 7.4: WARRANTY CLAIMS AND PERFORMANCE

◆Warranty claim(s) will only be accepted when being put forward within the applicable warranty period. Without prejudice to the foregoing, warranty claim(s) shall be made within 30 days upon the Customer because aware or should have been aware of the under performance of the Products.

◆If the Customer has a justified warranty claim covered by the Limited Warranty, an immediate notification shall be filed directly (i) to BUESUN, by mailing a registered letter in writing, or sending an email to BUESUN's email account listed hereunder; and (ii) to the vendor from whom the Customer purchased the Products. Together with the notification, the Customer shall provide: (I) the name and address of the Customer (and its distributor and installer, where applicable); (II) evidence showing the Product has been under-performing; and (III) other documents, evidence, or information as may be required by BUESUN or the agent appointed by BUESUN to deal with such warranty claim.

◆BUESUN or approved agent of BUESUN will examine the evidences and documents provided by the Customer and may request the Customer to deliver the allegedly defective Products to be designated by BUESUN or BUESUN's approved agent for further examination, inspection and verification.

◆After examination, inspection and verification of relevant evidences (and Product(s), where applicable):

◆If BUESUN or approved agent of BUESUN determines that it has been substantiated that the Products are performing below the applicable Warranted Capacity, before BUESUN or approved agent of BUESUN would be obligated to perform relevant warranty obligations pursuant to the Limited Warranty, the Customer will be required to immediately furnish to BUESUN or approved agent of BUESUN the original invoice(s) issued to the Customer when the Customer purchased the Product(s) concerns.

◆If BUESUN or approved agent of BUESUN determines that the result has indicated that the Product(s) has been performing in conformity with the applicable Warranted Capacity, the Customer shall be obligated to reimburse BUESUN and approved agent of BUESUN the costs and expenses incurred by them in relation to such testing, examination and verification.

◆No warranty claim(s) will be honored if:

◆The type or serial number of the Products have been altered, removed or been made illegible; or

◆The Customer fails to provide to BUESUN the original copies of:

● a full set of invoices issued by the vendor to the Customer for the Customer's purchase of the Products involved in the warranty claim(s);

● the warranty certificate issued by BUESUN; and

● other evidence, information, document and data that BUESUN might request the Customer to provide, to assess the actual performance of the Products; and

● a valid warranty claim is not submitted to BUESUN within 10 days after relevant applicable warranty period.