



Positioning: Last miles solution for city delivery&Logistics, Express, City Logistics and Supermarket Goods Transportation, cost-efficient short-distance transportation.

Certificate: EEC, DOT, OTTC

4 wheel, 1 driver seat

Size: 3600x1345x1765mm

Rate Load: 400kg -500kg

Curb weight: 530kg/580kg

Max Speed: 52km/hour

Four standard Color: White, Red, Blue, Grey (other colors OEM min order 10units)

Optional Configuration

EEC standard :105Ah LiFePO4 battery, 4000W motor, max distance 90km

206Ah LiFePO4 battery, 5000W motor, max distance 180km

Dimension as below

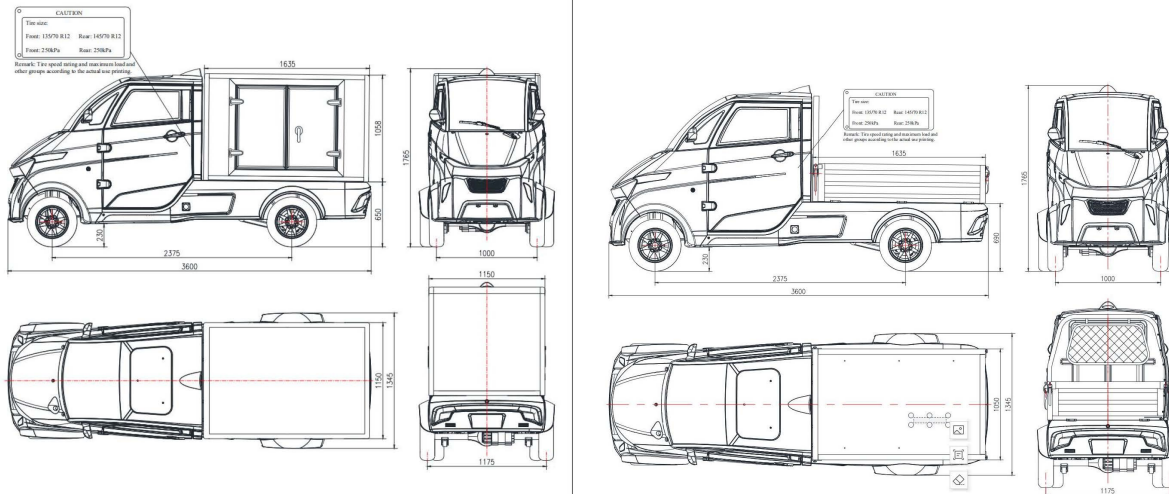

Cargo Box Type



Hopper



Refrigerator



One side door van



Wing door van



Advantage:

1. **CKD (Completely Knocked Down) assembly** reduce and save customs duty & transportation cost



2. **Car-sharing** Personal & Commercial APP, to manage and monitor all vehicles



3. **Fast charger** within 2-3 hours under home charger, power consumption cost of each 100Km is less than 0.5\$.

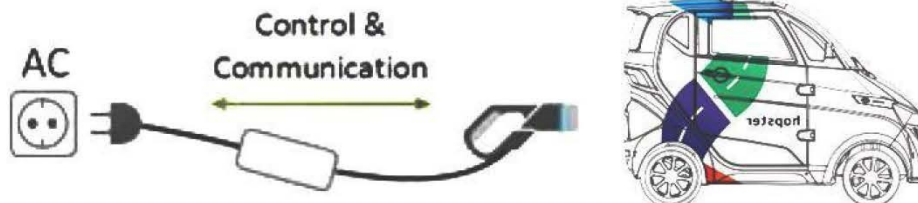



Details description:

1. Motor

AC motor with auto-hold function, powerful and water proof, lower noise, no carbon brush, maintenance-free, can improve the drive range.



2. Battery

Large-capacity, safety and long using life Lithium Iron Phosphate battery with BMS system. 2,000 times charging cycles(8-10 years) under working environment from -20 to 80 °C. And equipped with a fast charge ,to achieve full charge within 2-3 hours.



3. Electronic Control System

Use En-power electric control system , reliable and water-proof, steadily current control makes motor output much stronger and higher efficiency. Adopt the first-class AC motor control algorithm to achieve accurate control of motor speed.

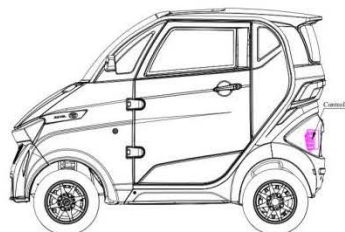

4. Front Windshield

3C certified tempered and laminated glass · Improve visual effect and safety performance.



5. Dashboard

LCD display, volt meter, power meter, kilometer and reverse camera, plus Bluetooth, MP5, USB connection.



6. Light System

Integral LED headlight, Turn lights, brake lights, reverse lights. Low power consumption and increase 50% more in light transmittance.



7. Plastic Cover

ABS resin , Luxury interior with sunroof. The most important mechanical properties of ABS have excellent comprehensive physical, impact resistance and toughness, Stability, two-thirds lighter weight than iron parts.

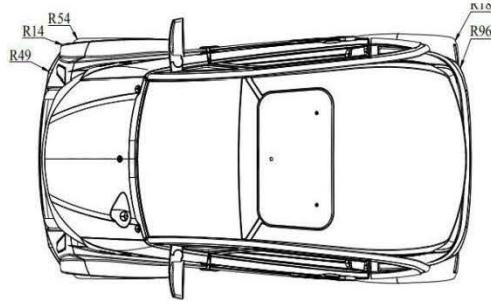

8. Brake System

Front-disc Rear-drum, two-circuit hydraulic brake, for the higher safety and stability.



9. Suspension System

The front axle and suspension are independent suspensions, simple structure and excellent stability. The integrated rear axle, axle housing welded by seamless steel tube, for lower noise, more durable and reliable.

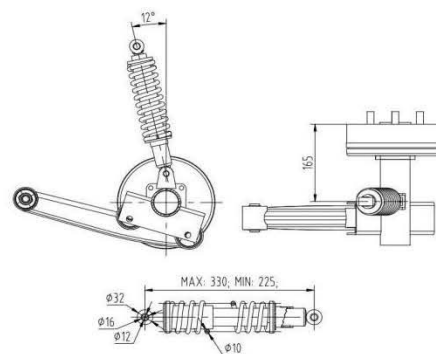
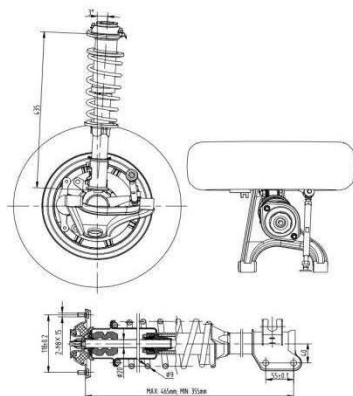

10. Steering System

Use double output steering gear box to adjust the gap automatically. there is no dead angle when rotate, Operate will be more lighter.



11. Frame & Chassis

GB Standard Steel, the surface under pickling & Photostating and corrosion-resistant treatment to ensure the excellent drive sense with stationary and solidity.

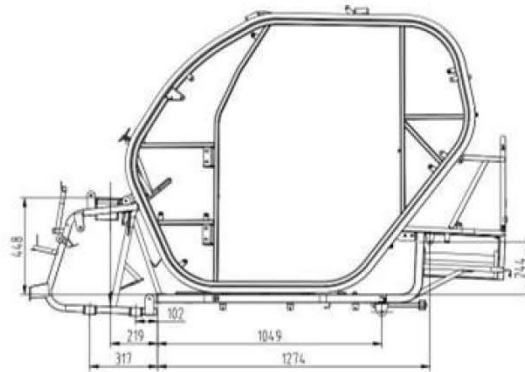

12. Seat

Genuine Leather + High Resilience PU for the comfortable and pleasant driving.



13. Tyre and Rim : Aluminum Wheels Hub, Vacuum Radial Tire.



14. Painting

Automobile-grade, Computer Painting Mixing, Robot-painting .



15. Cargo Box-- Cellular panel:

As special structure, with comprehensive strength, bending resistance, excellent properties such as electrical insulation, corrosion resistance and high temperature resistance. 70-90% lighter than solid plate.

